

DAVICOM Semiconductor, Inc.

DM8203

10/100 Mbps 2-port Ethernet Switch Controller
With MII / RMII Interface

DATA SHEET

Preliminary
Version: DM8203-DS-P05
October 23, 2008

CONTENT

1. GENERAL DESCRIPTION.....	8
2. BLOCK DIAGRAM.....	8
3. FEATURES	9
4. PIN CONFIGURATION	10
5. PIN DESCRIPTION	11
5.1 P2 MII / RMI / Reverse MII Interfaces.....	11
5.1.1 MII Interfaces	11
5.1.2 RMI Interfaces	11
5.1.3 Reverse MII Interfaces	12
5.2 EEPROM Interfaces.....	12
5.3 LED Pins.....	12
5.4 Clock Interface.....	13
5.5 Network Interface.....	13
5.6 Miscellaneous Pins.....	13
5.7 Power Pins.....	13
5.8 Strap pins table.....	14
6. CONTROL AND STATUS REGISTER SET.....	15
6.1 EEPROM & PHY Control Register (0BH)	16



6.2 EEPROM & PHY Address Register (0CH)	16
6.3 EPROM & PHY Data Register (0DH~0EH)	16
6.4 Vendor ID Register (28H~29H)	16
6.5 Product ID Register (2AH~2BH)	16
6.6 Port 2 driving capability Register (3AH)	16
6.7 Switch Control Register (52H)	17
6.8 VLAN Control Register (53H)	17
6.9 Switch Status Register (54H)	17
6.10 Per Port Control/Status Index Register (60H)	18
6.11 Per Port Control Data Register (61H)	18
6.12 Per Port Status Data Register (62H)	19
6.13 Per Port Forward Control Register (65H)	19
6.14 Per Port Ingress/Egress Control Register (66H)	20
6.15 Bandwidth Control Setting Register (67H)	21
6.16 Per Port Block Unicast ports Control Register (68H)	21
6.17 Per Port Block Multicast ports Control Register (69H)	22
6.18 Per Port Block Broadcast ports Control Register (6AH)	22
6.19 Per Port Block Unknown ports Control Register (6BH)	22
6.20 Per Port Priority Queue Control Register (6DH)	22
6.21 Per Port VLAN Tag Low Byte Register (6EH)	22



6.22 Per Port VLAN Tag High Byte Register (6FH)	23
6.23 MIB counters Port Index Register (80H).....	23
6.24 MIB counter Data Register (81H~84H).....	23
6.25 VLAN grouping table Registers (B0H~BFH).....	24
6.26 TOS Priority Map Registers (C0H~CFH).....	24
6.27 VLAN Priority Map Registers (D0H~D1H)	27
7. EEPROM FORMAT.....	28
8. PHY REGISTERS	31
8.1 Basic Mode Control Register (BMCR) – 00H.....	32
8.2 Basic Mode Status Register (BMSR) – 01H.....	33
8.3 PHY ID Identifier Register #1 (PHYID1) – 02H.....	34
8.4 PHY ID Identifier Register #2 (PHYID2) – 03H.....	34
8.5 Auto-negotiation Advertisement Register (ANAR) – 04H.....	35
8.6 Auto-negotiation Link Partner Ability Register (ANLPAR) – 05H.....	36
8.7 Auto-negotiation Expansion Register (ANER) - 06H.....	37
8.8 DAVICOM Specified Configuration Register (DSCR) – 10H.....	37
8.9 DAVICOM Specified Configuration and Status Register (DSCSR) – 11H.....	39
8.10 10BASE-T Configuration/Status (10BTCSR) – 12H.....	40
8.11 Power down Control Register (PWDOR) – 13H.....	40
8.12 (Specified config) Register – 14H	41



8.13 DAVICOM Specified Receive Error Counter Register (RECR) – 16H	42
8.14 DAVICOM Specified Disconnect Counter Register (DISCR) – 17H	42
8.15 Power Saving Control Register (PSCR) – 1DH	42
9. FUNCTIONAL DESCRIPTION	43
9.1 Serial Management Interface	43
9.2 Switch function:	44
9.2.1 Address Learning	44
9.2.2 Address Aging	44
9.2.3 Packet Forwarding	44
9.2.4 Inter-Packet Gap (IPG).....	44
9.2.5 Back-off Algorithm.....	44
9.2.6 Late Collision	44
9.2.7 Full Duplex Flow Control	44
9.2.8 Half Duplex Flow Control	44
9.2.9 Partition Mode.....	45
9.2.10 Broadcast Storm Filtering	45
9.2.11 Bandwidth Control.....	45
9.2.12 Port Monitoring Support	45
9.2.13 VLAN Support.....	46
9.2.13.1 Port-Based VLAN	46
9.2.13.2 802.1Q-Based VLAN.....	46
9.2.13.3 Tag/Untag	46
9.2.14 Priority Support.....	47
9.2.14.1 Port-Based Priority	47
9.2.14.2 802.1p-Based Priority.....	47
9.2.14.3 DiffServ-Based Priority.....	47
9.3 MII Interface	48
9.3.1 MII data interface.....	48
9.3.2 MII Serial Management	48



9.3.3 Serial Management Interface	49
9.3.4 Management Interface - Read Frame Structure.....	49
9.3.5 Management Interface - Write Frame Structure	49
9.4 Internal PHY functions	50
9.4.1 100Base-TX Operation.....	50
9.4.1.1 4B5B Encoder	50
9.4.1.2 Scrambler.....	50
9.4.1.3 Parallel to Serial Converter	50
9.4.1.4 NRZ to NRZI Encoder	50
9.4.1.5 MLT-3 Converter.....	50
9.4.1.6 MLT-3 Driver.....	50
9.4.1.7 4B5B Code Group	51
9.4.2 100Base-TX Receiver	52
9.4.2.1 Signal Detect	52
9.4.2.2 Adaptive Equalization.....	52
9.4.2.3 MLT-3 to NRZI Decoder.....	52
9.4.2.4 Clock Recovery Module.....	52
9.4.2.5 NRZI to NRZ.....	52
9.4.2.6 Serial to Parallel.....	52
9.4.2.7 Descrambler	52
9.4.2.8 Code Group Alignment.....	53
9.4.2.9 4B5B Decoder	53
9.4.3 10Base-T Operation	53
9.4.4 Collision Detection	53
9.4.5 Carrier Sense.....	53
9.4.6 Auto-Negotiation.....	53
9.5 HP Auto-MDIX Functional Descriptions	53
10. DC AND AC ELECTRICAL CHARACTERISTICS	55
10.1 Absolute Maximum Ratings	55
10.2 Operating Conditions	55



10.3 DC Electrical Characteristics	56
10.4 AC characteristics.....	56
10.4.1 Power On Reset Timing.....	56
10.4.2 Port 2 MII Interface Transmit Timing.....	57
10.4.3 Port 2 MII Interface Receive Timing.....	57
10.4.4 MII Management or host SMI Interface Timing	58
10.4.5 EEPROM timing	59
11. APPLICATION CIRCUIT	60
11.1 Main circuit.....	60
11.2 Application of Reverse MII.....	61
12. PACKAGE INFORMATION.....	62
13. ORDERING INFORMATION	63

1. General Description

The DM8203 is a fully integrated, high performance, and cost-effective fast Ethernet switch controller, two ports 10M/100Mbps PHY, and one port MII, Reverse MII or RMII interface.

The DM8203 with two ports 10M/100Mbps PHY, and one port MII, Reverse MII or RMII interface is a fully integrated, high performance, and cost-effective fast Ethernet switch controller

The internal memory of the DM8203 supports up to 1K uni-cast MAC address table, it is provided for three ports' usage. Each port of the DM8203 provides four priorities transmit queues that can be defined by port-based, 802.1p VLAN, or IP packet ToS field automatically, to fit the various bandwidth and latency requirement of data, voice, and video application.

Besides, it's internal memory has three ports usage, supporting up to 1K uni-case MAC address table. Each port of DM8203 provides four priorities transmit queens that can be defined by port-based,

802.1p VLAN, or IP packet ToS field automatically, applies to the various bandwidth and latency requirement of data, voice, and video application.

Each port also supports ingress and/or egress rate control to provide proper bandwidth. And up to 16 groups of 802.1Q VLAN with Tag/Un-tag functions are supported to provide efficient packet forwarding.

Each port, provide the MIB counters and loop-back capability and the build in memory self test (BIST) for system and board level diagnostic.

For proper bandwidth, each port also supports ingress and/or egress rate control, and up to 16 groups of 802.1Q VLAN with Tag/Un-tag functions support packet forwarding efficiently. Each port provides the MIB counters, loop-back capability and the build in memory self test (BIST) for system and board level diagnostic.

The integrated two ports PHY are compliant with IEEE 802.3u standards. The MII interface provides the flexibility to connect Ethernet PHY, and it can be configured to Reversed MII interface for SoC with MII interface. An alternative interface, the RMII interface, is also provided to connect the lower pin count Ethernet PHY or SoC with RMII interface.

2. Block Diagram

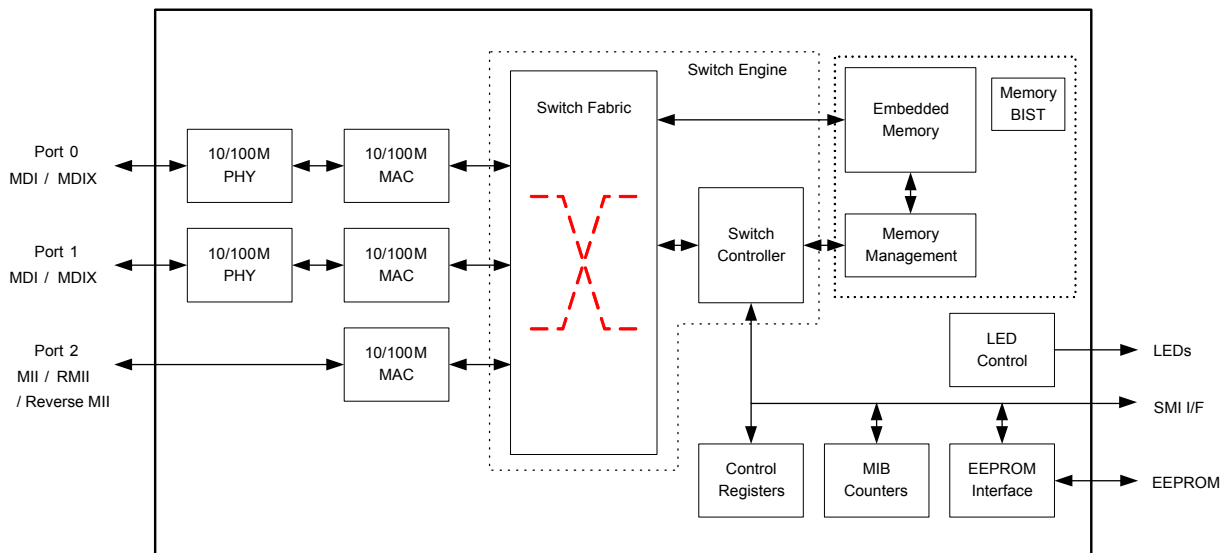

3. Features

- ❑ Ethernet Switch with two 10/100Mbps PHY, one MII/RMII
- ❑ Support Reverse-MII
- ❑ EEPROM interface for power up configurations
- ❑ Support HP Auto-MDIX
- ❑ Support IEEE 802.3x Flow Control in Full-duplex mode
- ❑ Support Back Pressure Flow Control in Half-duplex mode
- ❑ Per port support 4 priority queues by Port-based, 802.1P VLAN, and IP TOS priority
- ❑ Support 802.1Q VLAN up-to 16 VLAN group
- ❑ Support VLAN ID tag/untag options
- ❑ Per port support bandwidth, ingress and egress rate control
- ❑ Support Broadcast Storming filter function
- ❑ Support Store and Forward switching approach
- ❑ Support up-to 1K Uni-cast MAC addresses
- ❑ Support Serial data management interface
- ❑ Automatic aging scheme
- ❑ Support MIB counters for diagnostic
- ❑ 64-pin LQFP 1.8V/3.3V dual power and 3.3V I/O with 5V tolerant

4. Pin Configuration

64 pin LQFP:

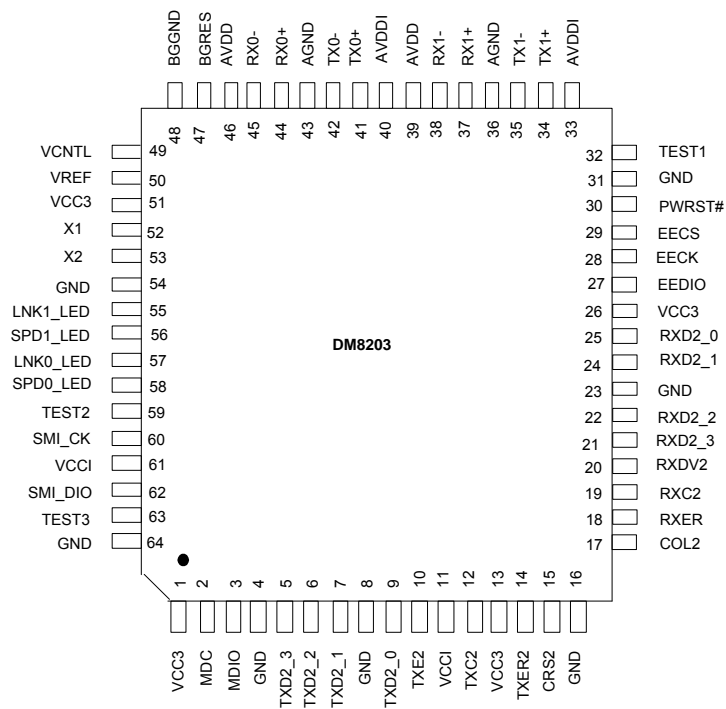

5. Pin Description

I = Input, O = Output, I/O = Input / Output, O/D = Open Drain, P = Power, PD=internal pull-low (about 50K Ohm)
= asserted Low

5.1 P2 MII / RMI / Reverse MII Interfaces

5.1.1 MII Interfaces

Pin No.	Pin Name	I/O	Description
2	MDC	O,PD	MII Serial Management Data Clock
3	MDIO	I/O	MII Serial Management Data
5,6,7,9	TXD2_3~0	O,PD	Port 2 MII Transmit Data 4-bit nibble data outputs (synchronous to the TXC2)
10	TXE2	O,PD	Port 2 MII Transmit Enable
12	TXC2	I/O	Port 2 MII Transmit Clock.
14	TXER2	O,PD	Port 2 MII Transmit Error
15	CRS2	I/O	Port 2 MII Carrier Sense
17	COL2	I/O	Port 2 MII Collision Detect.
18	RXER2	I	Port 2 MII Receive Error
19	RXC2	I	Port 2 MII Receive Clock
20	RXDV2	I	Port 2 MII Receive Data Valid
21,22,24,25	RXD2_3~0	I	Port 2 MII Receive Data 4-bit nibble data input (synchronous to RXC2)

5.1.2 RMI Interfaces

Pin No.	Pin Name	I/O	Description
2	MDC	O,PD	MII Serial Management Data Clock
3	MDIO	I/O	MII Serial Management Data
5,6	TXD2_3~2	O,PD	Reserved
7,9	TXD2_1~0	O,PD	RMI Transmit Data
10	TXE2	O,PD	RMI Transmit Enable.
12	TXC2	O	Reserved
14	TXER2	O	Port 2 MII Transmit Error
15	CRS2	I	RMI CRS_DV
17	COL2	I	Reserved, tie to ground in application.
18	RXER2	I	Reserved, tie to ground in application.
19	RXC2	I	50MHz reference clock.
20	RXDV2	I	Reserved, tie to ground in application.
21,22	RXD2_3~2	I	Reserved, tie to ground in application.
24,25	RXD2_1~0	I	RMI Receive Data.

5.1.3 Reverse MII Interfaces

Pin No.	Pin Name	I/O	Description
2	MDC	O,PD	Reserved
3	MDIO	I/O	Reserved
5,6,7,9	TXD2_3~0	O,PD	Port 2 MII Transmit Data 4-bit nibble data outputs (synchronous to the TXC2)
10	TXE2	O,PD	Port 2 MII Transmit Enable
12	TXC2	O	25MHz clock output
14	TXER2	O,PD	Port 2 MII Transmit Error
15	CRS2	O	Port 2 carrier sense output when TXE2 or RXDV2 asserted.
17	COL2	O	Port 2 collision output when TXE2 and RXDV2 asserted.
18	RXER2	I	Port 2 MII Receive Error
19	RXC2	I	Port 2 MII Receive Clock
20	RXDV2	I	Port 2 MII Receive Data Valid
21,22,24,25	RXD2_3~0	I	Port 2 MII Receive Data 4-bit nibble data input (synchronous to RXC2)

5.2 EEPROM Interfaces

Pin No.	Pin Name	I/O	Description
27	EEDIO	I/O	EEPROM Data In/Out
28	EECK	O,PD	EEPROM Serial Clock This pin is used as the clock for the EEPROM data transfer.
29	EECS	O,PD	EEPROM Chip Selection.

5.3 LED Pins

Pin No.	Pin Name	I/O	Description
55	LNK1_LED	O	Port 1 Link / Active LED It is the combined LED of link and carrier sense signal of the internal PHY1
56	SPD1_LED	O	Port 1 Speed LED Its low output indicates that the internal PHY1 is operated in 100M/S, or it is floating for the 10M mode of the internal PHY1
57	LNK0_LED	O	Port 0 Link / Active LED It is the combined LED of link and carrier sense signal of the internal PHY0
58	SPD0_LED	O	Port 0 Speed LED Its low output indicates that the internal PHY0 is operated in 100M/S, or it is floating for the 10M mode of the internal PHY0

**5.4 Clock Interface**

Pin No.	Pin Name	I/O	Description
52	X1	I	Crystal 25MHz In
53	X2	O	Crystal 25MHz Out

5.5 Network Interface

Pin No.	Pin Name	I/O	Description
34,35	TX1+/-	I/O	Port 1 TP TX These two pins are the Twisted Pair transmit in MDI mode or receive in MDIX mode.
37,38	RX1+/-	I/O	Port 1 TP RX These two pins are the Twisted Pair receive in MDI mode or transmit in MDIX mode.
41,42	TX0+/-	I/O	Port 0 TP TX These two pins are the Twisted Pair transmit in MDI mode or receive in MDIX mode.
44,45	RX0+/-	I/O	Port 0 TP RX These two pins are the Twisted Pair receive in MDI mode or transmit in MDIX mode.
47	BGRES	I/O	Band gap Pin Connect a 1.4K resistor to BGGND in application.
48	BGGND	P	Band gap Ground
49	VCNTL	I/O	1.8V Voltage control
50	VREF	O	Voltage Reference Connect a 0.1u capacitor to ground in application.

5.6 Miscellaneous Pins

Pin No.	Pin Name	I/O	Description
30	PWRST#	I	Power on Reset Low active with minimum 1ms
60	SMI_CK	I	Serial data management interface clock
62	SMI_DIO	I/O	Serial data management interface in / out
32	TEST1	I,PD	Tie to VCC3 in application
59	TEST2	I,PD	Tie to GND in application
63	TEST3	I,PD	Tie to VCC3 in application

5.7 Power Pins

Pin No.	Pin Name	I/O	Description
1,13,26,51	VCC3	P	Digital 3.3V
11,61	VCCI	P	Internal 1.8V core power
4,8,16,23,31,54,64	GND	P	Digital GND
39,46	AVDD3	P	Analog 3.3V power
33,40	AVDDI	P	Analog 1.8V power
36,43	AGND	P	Analog GND

5.8 Strap pins table

1: pull-high 1K~10K, 0: floating (default).

Pin No.	Pin Name	Description
28	EECK	0: Port 2 in force 10 Mbps mode 1: Port 2 in force 100 Mbps mode
29	EECS	0: Port 0 is TP mode 1: Port 0 is Fiber mode
14	TXER2	0: Port 1 is TP mode 1: Port 1 is Fiber mode
2	MDC	0: BIST 1: Bypass BIST
5	TXD2_3	TXD2_3
6	TXD2_2	TXD2_2
		Mode
		0 0 MII mode
		0 1 Reverse MII mode
		1 0 RMI mode
		1 1 Reserved (DO NOT USE)
7	TXD2_1	SMI device address 1
9	TXD2_0	SMI device address 0
10	TXE2	0: Port 2 normal mode 1: Port 2 force mode

6. Control and Status Register Set

The DM8203 implements several control and status registers, which can be accessed by the serial management interface. These CSRs are byte aligned. All CSRs are set to

their default values by hardware or software reset unless specified

Register	Description	Offset	Default value after reset
EPCR	EEPROM & PHY Control Register	0BH	00H
EPAR	EEPROM & PHY Address Register	0CH	40H
EPDRL	EEPROM & PHY Low Byte Data Register	0DH	XXH
EPDRH	EEPROM & PHY High Byte Data Register	0EH	XXH
VID	Vendor ID	28H-29H	0A46H
PID	Product ID	2AH-2BH	8203H
P2FRV	Port 2 driving capability Register	3AH	21H
SWITCHCR	SWITCH Control Register	52H	00H
VLANCR	VLAN Control Register	53H	00H
SWITCHSR	SWITCH Status Register	54H	00H
DSP1,2	DSP Control Register I,II	58H~59H	0000H
P_INDEX	Per Port Control/Status Index Register	60H	00H
P_CTRL	Per Port Control Data Register	61H	00H
P_STUS	Per Port Status Data Register	62H	00H
P_RATE	Per Port Ingress and Egress Rate Control Register	66H	00H
P_BW	Per Port Bandwidth Control Register	67H	00H
P_UNICAST	Per Port Block Unicast ports Control Register	68H	00H
P_MULTI	Per Port Block Multicast ports Control Register	69H	00H
P_BCAST	Per Port Block Broadcast ports Control Register	6AH	00H
P_UNKNWN	Per Port Block Unknown ports Control Register	6BH	00H
P_PRI	Per Port Priority Queue Control Register	6DH	00H
VLAN_TAGL	Per Port VLAN Tag Low Byte Register	6EH	01H
VLAN_TAGH	Per Port VLAN Tag High Byte Register	6FH	00H
P_MIB_IDX	Per Port MIB counter Index Register	80H	00H
MIB_DAT	MIB counter Data Register bit 0~7	81H	00H
MIB_DAT	MIB counter Data Register bit 8~15	82H	00H
MIB_DAT	MIB counter Data Register bit 16~23	83H	00H
MIB_DAT	MIB counter Data Register bit 24~31	84H	00H
PVLAN	Port-based VLAN mapping table registers	B0-BFH	0FH
TOS_MAP	TOS Priority Map Register	C0-CFH	00H~FFH
VLAN_MAP	VLAN priority Map Register	D0-D1H	50H,FAH

Key to Default

In the register description that follows, the default column takes the form:

<Reset Value>, <Access Type>

Where:

<Reset Value>:

- 1 Bit set to logic one
- 0 Bit set to logic zero
- X No default value

P = power on reset default value

H = hardware reset, by Reg. 52H bit 6, default value

E = default value from EEPROM setting

T = default value from strap pin

<Access Type>:

RO = Read only

RW = Read/Write

R/C = Read and Clear

RW/C1=Read/Write and Cleared by write 1

WO = Write only

Reserved bits should be written with 0.

Reserved bits are undefined on read access.

6.1 EEPROM & PHY Control Register (0BH)

Bit	Name	Default	Description
7:6	RESERVED	0,RO	Reserved
5	REEP	PH0,RW	Reload EEPROM. Driver needs to clear it up after the operation completes
4	WEP	PH0,RW	Write EEPROM Enable
3	EPOS	PH0,RW	EEPROM or PHY Operation Select When reset, select EEPROM; when set, select PHY
2	ERPRR	PH0,RW	EEPROM Read or PHY Register Read Command. Driver needs to clear it up after the operation completes.
1	ERPRW	PH0,RW	EEPROM Write or PHY Register Write Command. Driver needs to clear it up after the operation completes.
0	ERRE	PH0,RO	EEPROM Access Status or PHY Access Status When set, it indicates that the EEPROM or PHY access is in progress

6.2 EEPROM & PHY Address Register (0CH)

Bit	Name	Default	Description
7:6	PHY_ADR	PH01,RW	PHY Address bit 1 and 0; the PHY address bit [4:2] is force to 0.
5:0	EROA	PH0,RW	EEPROM Word Address or PHY Register Address

6.3 EPROM & PHY Data Register (0DH~0EH)

Bit	Name	Default	Description
7:0	EE_PHY_L	PH0,RW	EEPROM or PHY Low Byte Data (0DH) This data is made to write/read low byte of word address defined in Reg. CH to EEPROM or PHY
7:0	EE_PHY_H	PH0,RW	EEPROM or PHY High Byte Data (0EH) This data is made to write/read high byte of word address defined in Reg. CH to EEPROM or PHY

6.4 Vendor ID Register (28H~29H)

Bit	Name	Default	Description
7:0	VIDH	PE,0AH,RO	Vendor ID High Byte (29H)
7:0	VIDL	PE,46H,RO	Vendor ID Low Byte (28H)

6.5 Product ID Register (2AH~2BH)

Bit	Name	Default	Description
7:0	PIDH	PE,82H,RO	Product ID High Byte (2BH)
7:0	PIDL	PE,03H,RO	Product ID Low Byte (2AH)

6.6 Port 2 driving capability Register (3AH)

Bit	Name	Default	Description
7	Reserved	0,RO	Reserved
6:5	P2_CURR	P01,RW	Port 2 TXD/TXE Driving/Sinking Capability 00: 2mA 01: 4mA (default) 10: 6mA 11: 8mA
4:0	RESERVED	P01,RW	reserved

6.7 Switch Control Register (52H)

Bit	Name	Default	Description								
7	MEM_BIST	PH0,RO	Address Table Memory Test BIST Status 0: OK 1: Fail								
6	RST_SW	P0,RW	Reset Switch Core and auto clear after 10us								
5	RST_ANLG	P0,RW	Reset Analog PHY Core and auto clear after 10us								
4:3	SNF_PORT	PE0,RW	Sniffer Port Number Define the port number to act as the sniffer port <table border="1" style="margin-left: 20px;"> <tr> <td>00</td> <td>Port 0</td> </tr> <tr> <td>01</td> <td>Port 1</td> </tr> <tr> <td>10</td> <td>Port 2</td> </tr> <tr> <td>11</td> <td>Reserved</td> </tr> </table>	00	Port 0	01	Port 1	10	Port 2	11	Reserved
00	Port 0										
01	Port 1										
10	Port 2										
11	Reserved										
2	CRC_DIS	PE0,RW	CRC Checking Disable When set, the received CRC error packet also accepts to receive memory.								
1:0	AGE	PE0,RW	Address Table Aging 00: no aging 01: 64 ± 32 sec 10: 128 ± 64 sec 11: 256 ± 128 sec								

6.8 VLAN Control Register (53H)

Bit	Name	Default	Description
7	TOS6	PE0,RW	Full IP ToS Field for Priority Queue 1: check most significant 6-bit of TOS 0: check most significant 3-bit only of TOS
6	RESERVED	0,RO	Reserved
5	UNICAST	PE0,RW	Unicast packet can across VLAN boundary
4	VIDFF	PE0,RW	Replace VIDFF If the received packet is a tagged VLAN with VID equal to "FFF", its VLAN field is replaced with VLAN tag defined in Reg. 6EH and 6FH.
3	VID1	PE0,RW	Replace VID01 If the received packet is a tagged VLAN with VID equal to "001", its VLAN field is replaced with VLAN tag defined in Reg. 6EH and 6FH.
2	VID0	PE0,RW	Replace VID0 If the received packet is a tagged VLAN with VID equal to "000", its VLAN field is replaced with VLAN tag defined in Reg. 6EH and 6FH.
1	PRI	PE0,RW	Replace priority field in the tag with value define in Reg 6FH bit 7~5.
0	VLAN	PE0,RW	VLAN mode enable 1: 802.1Q base VLAN mode enable 0: port-base VLAN only

6.9 Switch Status Register (54H)

Bit	Name	Default	Description
7	MEM_BIST	PH0,RO	Address Table Memory Test BIST Status 0: OK 1: Fail
6:0	RESERVED	0,RO	Reserved

6.10 Per Port Control/Status Index Register (60H)

Bit	Name	Default	Description
7:5	reserved	PH0,RW	reserved
4:2	reserved	0,RO	reserved
1:0	INDEX	PH0,RW	Port index for register 61h~84h Write the port number to this register before write/read register 61h~84h.

6.11 Per Port Control Data Register (61H)

Bit	Name	Default	Description
7	RESERVED	PE0,RW	Reserved
6	PARTI_EN	PE0,RW	Enable Partition Detection
5	NO_DIS_RX	PE0,RW	Not Discard RX Packets when Ingress Bandwidth Control When received packets bandwidth reach Ingress bandwidth threshold, the packets over the threshold are not discarded but with flow control.
4	FLOW_DIS	PE0,RW	Flow control in full duplex mode, or back pressure in half duplex mode enable 0 – enable 1 – disable
3	BANDWIDTH	PE0,RW	Bandwidth Control 0: Control with Ingress and Egress separately, ref to Register 66h. 1: Control with Ingress or Egress, ref to Register 67h
2	BP_DIS	PE0,RW	Broadcast packet filter 0 – accept broadcast packets 1 – reject broadcast packets
1	MP_DIS	PE0,RW	Multicast packet filter 0 – accept multicast packets 1 – reject multicast packets
0	MP_STORM	PE0,RW	Broadcast Storm Control 0 – only broadcast packets storm are controlled 1 – Multicast packets also same as broadcast storm control.

6.12 Per Port Status Data Register (62H)

Bit	Name	Default	Description
7:6	RESERVED	P0,RO	Reserved
5	LP_FCS	P0,RO	Link Partner Flow Control Enable Status
4	BIST	P0,RO	BIST status 1: SRAM BIST fail 0: SRAM BIST pass
3	RESERVED	0,RO	Reserved
2	SPEED2	P0,RO	PHY Speed Status 0: 10Mbps, 1:100Mbps
1	FDX2	P0,RO	PHY Duplex Status 0: half-duplex, 1:full-duplex
0	LINK2	P0,RO	PHY Link Status 0: link fail, 1: link OK

6.13 Per Port Forward Control Register (65H)

Bit	Name	Default	Description
7	LOOPBACK	PH0,RW	Loop-Back Mode The transmitted packet will be forward to this port itself.
6	MONI_TX	PH0,RW	TX Packet Monitored The transmitted packets are also forward to sniffer port.
5	MONI_RX	PH0,RW	RX Packet Monitored The received packets are also forward to sniffer port.
4	DIS_BMP	PH0,RW	Broad/Multicast Not Monitored The received broadcast or multicast packets are not forward to sniffer port.
3	Reserved	PH0,RW	Reserved
2	TX_DIS	PH0,RW	Packet Transmit Disabled All packets can not be forward to this port.
1	RX_DIS	PH0,RW	Packet receive Disabled All received packets are discarded.
0	ADR_DIS	PH0,RW	Address Learning Disabled The Source Address (SA) field of packet is not learned to address table.

6.14 Per Port Ingress/Egress Control Register (66H)

Bit	Name	Default	Description
7:4	INGRESS	PE0,RW	<p>Ingress Rate Control</p> <p>These bits define the bandwidth threshold that received packets over the threshold are discarded.</p> <p>0000: none 0001: 64Kbps 0010: 128Kbps 0011: 256Kbps 0100: 512Kbps 0101: 1Mbps 0110: 2Mbps 0111: 4Mbps 1000: 8Mbps 1001: 16Mbps 1010: 32Mbps 1011: 48Mbps 1100: 64Mbps 1101: 72Mbps 1110: 80Mbps 1111: 88Mbps</p>
3:0	EGRESS	PE0,RW	<p>Egress Rate Control</p> <p>These bits define the bandwidth threshold that transmitted packets over the threshold are discarded.</p> <p>0000: none 0001: 64Kbps 0010: 128Kbps 0011: 256Kbps 0100: 512Kbps 0101: 1Mbps 0110: 2Mbps 0111: 4Mbps 1000: 8Mbps 1001: 16Mbps 1010: 32Mbps 1011: 48Mbps 1100: 64Mbps 1101: 72Mbps 1110: 80Mbps 1111: 88Mbps</p>

6.15 Bandwidth Control Setting Register (67H)

Bit	Name	Default	Description
7:4	BSTH	PE0,RW	Broadcast Storm Threshold These bits define the bandwidth threshold that received broadcast packets over the threshold are discarded 0000: no broadcast storm control 0001: 8K packets/sec 0010: 16K packets/sec 0011: 64K packets/sec 0100: 5% 0101: 10% 0110: 20% 0111: 30% 1000: 40% 1001: 50% 1010: 60% 1011: 70% 1100: 80% 1101: 90% 111X: no broadcast storm control
3:0	BW CTRL	PE0,RW	Received and Transmitted Bandwidth Control These bits define the bandwidth threshold that transmitted or received packets over the threshold are discarded 0000: none 0001: 64Kbps 0010: 128Kbps 0011: 256Kbps 0100: 512Kbps 0101: 1Mbps 0110: 2Mbps 0111: 4Mbps 1000: 8Mbps 1001: 16Mbps 1010: 32Mbps 1011: 48Mbps 1100: 64Mbps 1101: 72Mbps 1110: 80Mbps 1111: 88Mbps

6.16 Per Port Block Unicast ports Control Register (68H)

Bit	Name	Default	Description
7:4	RESERVED	PH0,RW	Reserved
3:0	BLK_UP	PH0,RW	Ports of Unicast Packet Be Blocked The received unicast packets are not forward to the assigned ports. Note that the assigned port definition: bit 0 for port 0, bit 1 for port 1,

6.17 Per Port Block Multicast ports Control Register (69H)

Bit	Name	Default	Description
7:4	RESERVED	PH0,RW	Reserved
3:0	BLK_MP	PH0,RW	Ports of Multicast Packet Be Blocked The received multicast packets are not forward to the assigned ports.

6.18 Per Port Block Broadcast ports Control Register (6AH)

Bit	Name	Default	Description
7:4	RESERVED	PH0,RW	Reserved
3:0	BLK_BP	PH0,RW	Ports of Broadcast Packet Be Blocked The received broadcast packets are not forward to the assigned ports.

6.19 Per Port Block Unknown ports Control Register (6BH)

Bit	Name	Default	Description
7:4	RESERVED	PH0,RW	Reserved
3:0	BLK_UKP	PH0,RW	Ports of Unknown Packet Be Blocked The packets with DA field not found in address table are not forward to the assigned ports.

6.20 Per Port Priority Queue Control Register (6DH)

Bit	Name	Default	Description
7	TAG_OUT	PE0,RW	Output Packet Tagging Enable The transmitted packets are containing VLAN tagged field.
6	PRI_DIS	PE0,RW	Priority Queue Disable Only one transmit queue is supported in this port.
5	WFQUE	PE0,RW	Weighted Fair Queuing 1: The priority weight for queue 3, 2, 1, and 0 is 8, 4, 2, and 1 respectively. 0: The queue 3 has the highest priority, and the next priorities are queue 2, 1, and 0 respectively.
4	TOS_PRI	PE0,RW	Priority ToS over VLAN If an IP packet with VLAN tag, the priority of this packet is decode from ToS field.
3	TOS_OFF	PE0,RW	ToS Priority Classification Disable The priority information from ToS field of IP packet is ignored.
2	PRI_OFF	PE0,RW	802.1 p Priority Classification Disable The priority information from VLAN tag field is ignored.
1:0	P_PRI	PE0,RW	Port Base priority The priority queue number in port base. 00= queue 0, 01=queue 1, 10=queue 2, 11=queue 3

6.21 Per Port VLAN Tag Low Byte Register (6EH)

Bit	Name	Default	Description
7:0	VID70	PE01,RW	VID[7:0]

6.22 Per Port VLAN Tag High Byte Register (6FH)

Bit	Name	Default	Description
7:5	PRI	PE0,RW	Tag [15:13]
4	CFI	PE0,RW	Tag[12]
3:0	VID18	PE0,RW	VID[11:8]

6.23 MIB counters Port Index Register (80H)

Bit	Name	Default	Description
7	READY	P0,RO	MIB counter data is ready When this register is written with INDEX data, this bit is cleared and the MIB counter reading is in progress. After end of read MIB counter, the MIB data is loaded into register 81H~84H, and this bit is set to indicate that the MIB data is ready.
6:5	reserved	0,RO	Reserved
4:0	INDEX	PHS0,RW	MIB counter index 0~9, each counter is 32-bit in Register 81h~84h. Write the MIB counter index to this register before read them.

6.24 MIB counter Data Register (81H~84H)

Bit	Name	Default	Description
81H	Counter0	X,RO	Counter's data bit 7~0
82H	Counter1	X,RO	Counter's data bit 15~8
83H	Counter2	X,RO	Counter's data bit 23~16
84H	Counter3	X,RO	Counter's data bit 31~24

MIB counter: RX Byte Counter Registers (INDEX 00H)

MIB counter: RX Uni-cast Packet Counter Registers (INDEX 01H)

MIB counter: RX Multi-cast Packet Counter Registers (INDEX 02H)

MIB counter: RX Discard Packet Counter Registers (INDEX 03H)

MIB counter: RX Error Packet Counter Registers (INDEX 04H)

MIB counter: TX Byte Counter Registers (INDEX 05H)

MIB counter: TX Uni-cast Packet Counter Registers (INDEX 06H)

MIB counter: TX Multi-cast Packet Counter Registers (INDEX 07H)

MIB counter: TX Discard Packet Counter Registers (INDEX 08H)

MIB counter: TX Error Packet Counter Registers (INDEX 09H)

6.25 VLAN grouping table Registers (B0H~BFH)

Define the port member in VLAN group

There are 16 VLAN group that defined in Reg. B0H~BFH.

Group 0 defined in Reg. B0H, and group 1 defined in Reg. B1H ... and so on.

Bit	Name	Default	Description
7:4	RESERVED	PE0,RO	Reserved
2	PORT_P2	PE1,RW	Mapping to port 2
1	PORT_P1	PE1,RW	Mapping to port 1
0	PORT_P0	PE1,RW	Mapping to port 0

6.26 TOS Priority Map Registers (C0H~CFH)

Define the 6-bit or 3-bit of ToS field mapping to 2-bit priority queue number.

In 6-bit type, the Reg. 53H bit 7 is "1", Reg. C0H bit [1:0] define the mapping for ToS value 0, Reg. 60H bit [3:2] define the mapping for ToS value 1, ... and so on, till Reg. CFH bit [7:6] define ToS value 63.

In 3-bit type, Reg. C0H bit [1:0] defines the mapping for ToS value 0, Reg. 60H bit [3:2] defines the mapping for ToS value 1 ... and so on, and till Reg. C1H bit [7:6] define ToS value 7.

C0H:

Bit	Name	Default	Description
7:6	TOS3	PE0/1,RW	If bit 53H.7 =1 :TOS[7:2]=03H, otherwise TOS[7:5]=03H
5:4	TOS2	PE0/1,RW	If bit 53H.7 =1 :TOS[7:2]=02H, otherwise TOS[7:5]=02H
3:2	TOS1	PE0,RW	If bit 53H.7 =1 :TOS[7:2]=01H, otherwise TOS[7:5]=01H
1:0	TOS0	PE0,RW	If bit 53H.7 =1 :TOS[7:2]=00H, otherwise TOS[7:5]=00H

C1H:

Bit	Name	Default	Description
7:6	TOS7	PE0/3,RW	If bit 53H.7 =1 :TOS[7:2]=07H, otherwise TOS[7:5]=07H
5:4	TOS6	PE0/3,RW	If bit 53H.7 =1 :TOS[7:2]=06H, otherwise TOS[7:5]=06H
3:2	TOS5	PE0/2,RW	If bit 53H.7 =1 :TOS[7:2]=05H, otherwise TOS[7:5]=05H
1:0	TOS4	PE0/2,RW	If bit 53H.7 =1 :TOS[7:2]=04H, otherwise TOS[7:5]=04H

C2H:

Bit	Name	Default	Description
7:6	TOSB	PE0,RW	If bit 53H.7 =1 :TOS[7:2]=0BH
5:4	TOSA	PE0,RW	If bit 53H.7 =1 :TOS[7:2]=0AH
3:2	TOS9	PE0,RW	If bit 53H.7 =1 :TOS[7:2]=09H
1:0	TOS8	PE0,RW	If bit 53H.7 =1 :TOS[7:2]=08H

C3H:

Bit	Name	Default	Description
7:6	TOSF	PE0,RW	If bit 53H.7 =1 :TOS[7:2]=0FH
5:4	TOSE	PE0,RW	If bit 53H.7 =1 :TOS[7:2]=0EH
3:2	TOSD	PE0,RW	If bit 53H.7 =1 :TOS[7:2]=0DH
1:0	TOSC	PE0,RW	If bit 53H.7 =1 :TOS[7:2]=0CH

C4H:

Bit	Name	Default	Description
7:6	TOS13	PE1,RW	If bit 53H.7 =1 :TOS[7:2]=13H
5:4	TOS12	PE1,RW	If bit 53H.7 =1 :TOS[7:2]=12H
3:2	TOS11	PE1,RW	If bit 53H.7 =1 :TOS[7:2]=11H
1:0	TOS10	PE1,RW	If bit 53H.7 =1 :TOS[7:2]=10H

C5H:

Bit	Name	Default	Description
7:6	TOS17	PE1,RW	If bit 53H.7 =1 :TOS[7:2]=17H
5:4	TOS16	PE1,RW	If bit 53H.7 =1 :TOS[7:2]=16H
3:2	TOS15	PE1,RW	If bit 53H.7 =1 :TOS[7:2]=15H
1:0	TOS14	PE1,RW	If bit 53H.7 =1 :TOS[7:2]=14H

C6H:

Bit	Name	Default	Description
7:6	TOS1B	PE1,RW	If bit 53H.7 =1 :TOS[7:2]=1BH
5:4	TOS1A	PE1,RW	If bit 53H.7 =1 :TOS[7:2]=1AH
3:2	TOS19	PE1,RW	If bit 53H.7 =1 :TOS[7:2]=19H
1:0	TOS18	PE1,RW	If bit 53H.7 =1 :TOS[7:2]=18H

C7H:

Bit	Name	Default	Description
7:6	TOS1F	PE1,RW	If bit 53H.7 =1 :TOS[7:2]=1FH
5:4	TOS1E	PE1,RW	If bit 53H.7 =1 :TOS[7:2]=1EH
3:2	TOS1D	PE1,RW	If bit 53H.7 =1 :TOS[7:2]=1DH
1:0	TOS1C	PE1,RW	If bit 53H.7 =1 :TOS[7:2]=1CH

C8H:

Bit	Name	Default	Description
7:6	TOS23	PE2,RW	If bit 53H.7 =1 :TOS[7:2]=23H
5:4	TOS22	PE2,RW	If bit 53H.7 =1 :TOS[7:2]=22H
3:2	TOS21	PE2,RW	If bit 53H.7 =1 :TOS[7:2]=21H
1:0	TOS20	PE2,RW	If bit 53H.7 =1 :TOS[7:2]=20H

C9H:

Bit	Name	Default	Description
7:6	TOS27	PE2,RW	If bit 53H.7 =1 :TOS[7:2]=27H
5:4	TOS26	PE2,RW	If bit 53H.7 =1 :TOS[7:2]=26H
3:2	TOS25	PE2,RW	If bit 53H.7 =1 :TOS[7:2]=25H
1:0	TOS24	PE2,RW	If bit 53H.7 =1 :TOS[7:2]=24H

CAH:

Bit	Name	Default	Description
7:6	TOS2B	PE2,RW	If bit 53H.7 =1 :TOS[7:2]=2BH
5:4	TOS2A	PE2,RW	If bit 53H.7 =1 :TOS[7:2]=2AH
3:2	TOS29	PE2,RW	If bit 53H.7 =1 :TOS[7:2]=29H
1:0	TOS28	PE2,RW	If bit 53H.7 =1 :TOS[7:2]=28H

CBH:

Bit	Name	Default	Description
7:6	TOS2F	PE2,RW	If bit 53H.7 =1 :TOS[7:2]=2FH
5:4	TOS2E	PE2,RW	If bit 53H.7 =1 :TOS[7:2]=2EH
3:2	TOS2D	PE2,RW	If bit 53H.7 =1 :TOS[7:2]=2DH
1:0	TOS2C	PE2,RW	If bit 53H.7 =1 :TOS[7:2]=2CH

CCH:

Bit	Name	Default	Description
7:6	TOS33	PE3,RW	If bit 53H.7 =1 :TOS[7:2]=33H
5:4	TOS32	PE3,RW	If bit 53H.7 =1 :TOS[7:2]=32H
3:2	TOS31	PE3,RW	If bit 53H.7 =1 :TOS[7:2]=31H
1:0	TOS30	PE3,RW	If bit 53H.7 =1 :TOS[7:2]=30H

CDH:

Bit	Name	Default	Description
7:6	TOS37	PE3,RW	If bit 53H.7 =1 :TOS[7:2]=37H
5:4	TOS36	PE3,RW	If bit 53H.7 =1 :TOS[7:2]=36H
3:2	TOS35	PE3,RW	If bit 53H.7 =1 :TOS[7:2]=35H
1:0	TOS34	PE3,RW	If bit 53H.7 =1 :TOS[7:2]=34H

CEH:

Bit	Name	Default	Description
7:6	TOS3B	PE3,RW	If bit 53H.7 =1 :TOS[7:2]=3BH
5:4	TOS3A	PE3,RW	If bit 53H.7 =1 :TOS[7:2]=3AH
3:2	TOS39	PE3,RW	If bit 53H.7 =1 :TOS[7:2]=39H
1:0	TOS38	PE3,RW	If bit 53H.7 =1 :TOS[7:2]=38H

CFH:

Bit	Name	Default	Description
7:6	TOS3F	PE3,RW	If bit 53H.7 =1 :TOS[7:2]=3FH
5:4	TOS3E	PE3,RW	If bit 53H.7 =1 :TOS[7:2]=3EH
3:2	TOS3D	PE3,RW	If bit 53H.7 =1 :TOS[7:2]=3DH
1:0	TOS3C	PE3,RW	If bit 53H.7 =1 :TOS[7:2]=3CH

6.27 VLAN Priority Map Registers (D0H~D1H)

Define the 3-bit of priority field VALN mapping to 2-bit priority queue number.

D0H:

Bit	Name	Default	Description
7:6	TAG3	PE1,RW	VLAN priority tag value = 03H
5:4	TAG2	PE1,RW	VLAN priority tag value = 02H
3:2	TAG1	PE0,RW	VLAN priority tag value = 01H
1:0	TAG0	PE0,RW	VLAN priority tag value = 00H

D1H:

Bit	Name	Default	Description
7:6	TAG7	PE3,RW	VLAN priority tag value = 07H
5:4	TAG6	PE3,RW	VLAN priority tag value = 06H
3:2	TAG5	PE2,RW	VLAN priority tag value = 05H
1:0	TAG4	PE2,RW	VLAN priority tag value = 04H

7. EEPROM Format

name	Word	Description
RESERVED	0~2	Reserved
Auto Load Control	3	[1:0] Auto Load Control
Vendor ID	4	Vendor ID
Product ID	5	Product ID
RESERVED	6	Reserved
PHY Control	7	PHY Control
RESERVED	8~15	Reserved
Control	16	Bit 1:0=01: Accept setting of WORD 17,18 Bit 3:2=01: Accept setting of WORD 19~26 Bit 5:4=01: Accept setting of WORD 27~30 Bit 7:6=01: Accept setting of WORD 31 Bit 9:8=01: Accept setting of WORD 32~39 Bit 11:10=01: Accept setting of WORD 40~47 Bit 15:12 =01: Reserved
Switch Control 1	17	When word 16 bit 1:0 is "01", after power on reset: This word bit 7~0 will be loaded to Reg. 52H bit 7~0 This word bit 15~8 will be loaded to Reg. 53H bit 7~0
Switch Control 2	18	When word 16 bit 1:0 is "01", after power on reset: This word bit 7~0 will be loaded to Reg. 58H bit 7~0 This word bit 15~8 will be loaded to Reg. 59H bit 7~0
Port 0 Control 1	19	When word 16 bit 3:2 is "01", after power on reset: This word bit 7~0 will be loaded to port 0 Reg. 61H bit 7~0 This word bit 15~8 will be loaded to port 0 Reg. 66H bit 7~0
Port 0 Control 2	20	When word 16 bit 3:2 is "01", after power on reset: This word bit 7~0 will be loaded to port 0 Reg. 67H bit 7~0 This word bit 15~8 will be loaded to port 0 Reg. 6DH bit 7~0
Port 1 Control 1	21	When word 16 bit 3:2 is "01", after power on reset: This word bit 7~0 will be loaded to port 1 Reg. 61H bit 7~0 This word bit 15~8 will be loaded to port 1 Reg. 66H bit 7~0
Port 1 Control 2	22	When word 16 bit 3:2 is "01", after power on reset: This word bit 7~0 will be loaded to port 1 Reg. 67H bit 7~0 This word bit 15~8 will be loaded to port 1 Reg. 6DH bit 7~0
Port 2 Control 1	23	When word 16 bit 3:2 is "01", after power on reset: This word bit 7~0 will be loaded to port 2 Reg. 61H bit 7~0 This word bit 15~8 will be loaded to port 2 Reg. 66H bit 7~0
Port 2 Control 2	24	When word 16 bit 3:2 is "01", after power on reset: This word bit 7~0 will be loaded to port 2 Reg. 67H bit 7~0 This word bit 15~8 will be loaded to port 2 Reg. 6DH bit 7~0
RESERVED	25-26	Reserved
Port 0 VLAN Tag	27	When word 16 bit 5:4 is "01", after power on reset: This word bit 7~0 will be loaded to port 0 Reg. 6EH bit 7~0 This word bit 15~8 will be loaded to port 0 Reg. 6FH bit 7~0
Port 1 VLAN Tag	28	When word 16 bit 5:4 is "01", after power on reset: This word bit 7~0 will be loaded to port 1 Reg. 6EH bit 7~0 This word bit 15~8 will be loaded to port 1 Reg. 6FH bit 7~0
Port 2 VLAN Tag	29	When word 16 bit 5:4 is "01", after power on reset:



		This word bit 7~0 will be loaded to port 2 Reg. 6EH bit 7~0 This word bit 15~8 will be loaded to port 2 Reg. 6FH bit 7~0
RESERVED	30	Reserved
VLAN Priority Map	31	When word 16 bit 7:6 is "01", after power on reset: This word bit 7~0 will be loaded to Reg. D0H bit 7~0 This word bit 15~8 will be loaded to Reg. D1H bit 7~0
Port VLAN Group 0,1	32	When word 16 bit 9:8 is "01", after power on reset: This word bit 7~0 will be loaded to Reg. B0H bit 7~0 This word bit 15~8 will be loaded to Reg. B1H bit 7~0
Port VLAN Group 2,3	33	When word 16 bit 9:8 is "01", after power on reset: This word bit 7~0 will be loaded to Reg. B2H bit 7~0 This word bit 15~8 will be loaded to Reg. B3H bit 7~0
Port VLAN Group 4,5	34	When word 16 bit 9:8 is "01", after power on reset: This word bit 7~0 will be loaded to Reg. B4H bit 7~0 This word bit 15~8 will be loaded to Reg. B5H bit 7~0
Port VLAN Group 6,7	35	When word 16 bit 9:8 is "01", after power on reset: This word bit 7~0 will be loaded to Reg. B6H bit 7~0 This word bit 15~8 will be loaded to Reg. B7H bit 7~0
Port VLAN Group 8,9	36	When word 16 bit 9:8 is "01", after power on reset: This word bit 7~0 will be loaded to Reg. B8H bit 7~0 This word bit 15~8 will be loaded to Reg. B9H bit 7~0
Port VLAN Group 10,11	37	When word 16 bit 9:8 is "01", after power on reset: This word bit 7~0 will be loaded to Reg. BAH bit 7~0 This word bit 15~8 will be loaded to Reg. BBH bit 7~0
Port VLAN Group 12,13	38	When word 16 bit 9:8 is "01", after power on reset: This word bit 7~0 will be loaded to Reg. BCH bit 7~0 This word bit 15~8 will be loaded to Reg. BDH bit 7~0
Port VLAN Group 14,15	39	When word 16 bit 9:8 is "01", after power on reset: This word bit 7~0 will be loaded to Reg. BEH bit 7~0 This word bit 15~8 will be loaded to Reg. BFH bit 7~0
ToS Priority Map 0	40	When word 16 bit 11:10 is "01", after power on reset: This word bit 7~0 will be loaded to Reg. C0H bit 7~0 This word bit 15~8 will be loaded to Reg. C1H bit 7~0
ToS Priority Map 1	41	When word 16 bit 11:10 is "01", after power on reset: This word bit 7~0 will be loaded to Reg. C2H bit 7~0 This word bit 15~8 will be loaded to Reg. C3H bit 7~0
ToS Priority Map 2	42	When word 16 bit 11:10 is "01", after power on reset: This word bit 7~0 will be loaded to Reg. C4H bit 7~0 This word bit 15~8 will be loaded to Reg. C5H bit 7~0
ToS Priority Map 3	43	When word 16 bit 11:10 is "01", after power on reset: This word bit 7~0 will be loaded to Reg. C6H bit 7~0 This word bit 15~8 will be loaded to Reg. C7H bit 7~0
ToS Priority Map 4	44	When word 16 bit 11:10 is "01", after power on reset: This word bit 7~0 will be loaded to Reg. C8H bit 7~0 This word bit 15~8 will be loaded to Reg. C9H bit 7~0
ToS Priority Map 5	45	When word 16 bit 11:10 is "01", after power on reset: This word bit 7~0 will be loaded to Reg. CAH bit 7~0 This word bit 15~8 will be loaded to Reg. CBH bit 7~0
ToS Priority Map 6	46	When word 16 bit 11:10 is "01", after power on reset:



DM8203

2-port switch with MII / RMI Interface

		This word bit 7~0 will be loaded to Reg. CCH bit 7~0 This word bit 15~8 will be loaded to Reg. CDH bit 7~0
ToS Priority Map 7	47	When word 16 bit 11:10 is "01", after power on reset: This word bit 7~0 will be loaded to Reg. CEH bit 7~0 This word bit 15~8 will be loaded to Reg. CFH bit 7~0



8. PHY Registers

MII Register Description

ADD	Name	15	14	13	12	11	10	9	8	7	6	5	4	3	2	1	0	
00H	CONTR OL	Reset	Loop back	Speed select	Auto-N Enable	Power Down	Isolate	Restart Auto-N	Full Duplex	Coll. Test	Reserved							
		0	0	1	1	0	0	0	1	0	000 0000							
01H	STATUS	T4 Cap.	TX FDX Cap.	TX HDX Cap.	10 FDX Cap.	10 HDX Cap.	Reserved				Pream. Supr.	Auto-N Compl.	Remote Fault	Auto-N Cap.	Link Status	Jabber Detect	Ext'd Cap.	
		0	1	1	1	1	0000				1	0	0	1	0	0	1	
02H	PHYID1	0	0	0	0	0	0	0	1	1	0	0	0	0	0	0	1	
03H	PHYID2	1	0	1	1	1	0	Model No.				Version No.						
						01011				0000								
04H	Auto-Neg. Advertise	Next Page	FLP Rcv	Remote Fault	Reserved		FC Adv	T4 Adv	TX FDX Adv	TX HDX Adv	10 FDX Adv	10 HDX Adv	Advertised Protocol Selector Field					
05H	Link Part. Ability	LP Next Page	LP Ack	LP RF	Reserved		LP FC	LP T4	LP TX FDX	LP TX HDX	LP 10 FDX	LP 10 HDX	Link Partner Protocol Selector Field					
06H	Auto-Neg. Expansion	Reserved										Pardet Fault	LP Next Pg Able	Next Pg Able	New Pg Rcv	LP AutoN Cap.		
10H	Specified Config.	BP 4B5B	BP SCR	BP ALIGN	BP_AD P OK	Reserve dr	TX	Reserve d	Reserve d	Force 100LNK	Reserve d	Reserve d	RPDCTR -EN	Reset St. Mch	Pream. Supr.	Sleep mode	Reserved	
11H	Specified Conf/Stat	100 FDX	100 HDX	10 FDX	10 HDX	Reserve d	Reverse d	Reverse d	PHY ADDR [4:0]				Auto-N. Monitor Bit [3:0]					
12H	10T Conf/Stat	Rsvd	LP Enable	HBE Enable	SQUE Enable	JAB Enable	Reserve d	Reserved									Polarity Reverse	
13H	PWDOR	Reserved							PD10DR V	PD100I	PDchip	PDorm	PDaeq	PDdrv	PDdecl	PDdedo	PD10	
14H	Specified config	TSTSE1	TSTSE2	FORCE_TXSD	FORCE_FEF	PREA_MBLEX	TX10M_PWR	NWAY_PWR	Reserved	MDIX_C NTL	AutoNeg_dlpbk	Mdix_fix Value	Mdix_dow n	MonSel1	MonSel0	Reserve d	PD_valu e	
16H	RCVER	Receiver Error Counter																
17H	DIS_conn ect	Reversed								Disconnect_counter								
1DH	PSCR	Reversed				PREA_MBLEX	AMPLIT UDE	TX_PW R	Reversed									

Key to Default

In the register description that follows, the default column takes the form:

<Reset Value>, <Access Type> / <Attribute(s)>

Where:

<Reset Value>:

- 1 Bit set to logic one
- 0 Bit set to logic zero
- X No default value

<Access Type>:

RO = Read only, RW = Read/Write

<Attribute (s)>:

SC = Self clearing, P = Value permanently set

8.1 Basic Mode Control Register (BMCR) – 00H

Bit	Bit Name	Default	Description
15	Reset	0, RW/SC	Reset 1=Software reset 0=Normal operation This bit sets the status and controls the PHY registers to their default states. This bit, which is self-clearing, will keep returning a value of one until the reset process is completed
14	Loopback	0, RW	Loopback Loop-back control register 1 = Loop-back enabled 0 = Normal operation When in 100Mbps operation mode, setting this bit may cause the descrambler to lose synchronization and produce a 720ms "dead time" before any valid data appears at the MII receive outputs
13	Speed selection	1, RW	Speed Select 1 = 100Mbps 0 = 10Mbps Link speed may be selected either by this bit or by auto-negotiation. When auto-negotiation is enabled and bit 12 is set, this bit will return auto-negotiation selected medium type
12	Auto-negotiation enable	1, RW	Auto-negotiation Enable 1 = Auto-negotiation is enabled, bit 8 and 13 will be in auto-negotiation status
11	Power down	0, RW	Power Down While in the power-down state, the PHY should respond to management transactions. During the transition to power-down state and while in the power-down state, the PHY should not generate spurious signals on the MII 1=Power down 0=Normal operation
10	Isolate	0,RW	Isolate Force to 0 in application.
9	Restart Auto-negotiation	0,RW/SC	Restart Auto-negotiation 1 = Restart auto-negotiation. Re-initiates the auto-negotiation process. When auto-negotiation is disabled (bit 12 of this register cleared), this bit has no function and it should be cleared. This bit is self-clearing and it will keep returning to a value of 1 until auto-negotiation is initiated by the DM8203. The operation of the auto-negotiation process will not be affected by the management entity that clears this bit 0 = Normal operation
8	Duplex mode	1,RW	Duplex Mode 1 = Full duplex operation. Duplex selection is allowed when Auto-negotiation is disabled (bit 12 of this register is cleared). With auto-negotiation enabled, this bit reflects the duplex capability selected by auto-negotiation 0 = Normal operation



7	Collision test	0,RW	Collision Test 1 = Collision test enabled. When set, this bit will cause the COL signal to be asserted in response to the assertion of TX_EN in internal MII interface. 0 = Normal operation
6-0	Reserved	0,RO	Reserved Read as 0, ignore on write

8.2 Basic Mode Status Register (BMSR) – 01H

Bit	Bit Name	Default	Description
15	100BASE-T4	0,RO/P	100BASE-T4 Capable 1 = DM8203 is able to perform in 100BASE-T4 mode 0 = DM8203 is not able to perform in 100BASE-T4 mode
14	100BASE-TX full-duplex	1,RO/P	100BASE-TX Full Duplex Capable 1 = DM8203 is able to perform 100BASE-TX in full duplex mode 0 = DM8203 is not able to perform 100BASE-TX in full duplex mode
13	100BASE-TX half-duplex	1,RO/P	100BASE-TX Half Duplex Capable 1 = DM8203 is able to perform 100BASE-TX in half duplex mode 0 = DM8203 is not able to perform 100BASE-TX in half duplex mode
12	10BASE-T full-duplex	1,RO/P	10BASE-T Full Duplex Capable 1 = DM8203 is able to perform 10BASE-T in full duplex mode 0 = DM8203 is not able to perform 10BASE-TX in full duplex mode
11	10BASE-T half-duplex	1,RO/P	10BASE-T Half Duplex Capable 1 = DM8203 is able to perform 10BASE-T in half duplex mode 0 = DM8203 is not able to perform 10BASE-T in half duplex mode
10-7	Reserved	0,RO	Reserved Read as 0, ignore on write
6	MF preamble suppression	1,RO	MII Frame Preamble Suppression 1 = PHY will accept management frames with preamble suppressed 0 = PHY will not accept management frames with preamble suppressed
5	Auto-negotiation Complete	0,RO	Auto-negotiation Complete 1 = Auto-negotiation process completed 0 = Auto-negotiation process not completed
4	Remote fault	0, RO	Remote Fault 1 = Remote fault condition detected (cleared on read or by a chip reset). Fault criteria and detection method is DM8203 implementation specific. This bit will set after the RF bit in the ANLPAR (bit 13, register address 05) is set 0 = No remote fault condition detected
3	Auto-negotiation ability	1,RO/P	Auto Configuration Ability 1 = DM8203 is able to perform auto-negotiation 0 = DM8203 is not able to perform auto-negotiation
2	Link status	0,RO	Link Status 1 = Valid link is established (for either 10Mbps or 100Mbps operation) 0 = Link is not established



DM8203

2-port switch with MII / RMI Interface

			The link status bit is implemented with a latching function, so that the occurrence of a link failure condition causes the link status bit to be cleared and remain cleared until it is read via the management interface
1	Jabber detect	0, RO	Jabber Detect 1 = Jabber condition detected 0 = No jabber This bit is implemented with a latching function. Jabber conditions will set this bit unless it is cleared by a read to this register through a management interface or a DM8203 reset. This bit works only in 10Mbps mode
0	Extended capability	1,RO/P	Extended Capability 1 = Extended register capable 0 = Basic register capable only

8.3 PHY ID Identifier Register #1 (PHYID1) – 02H

The PHY Identifier Registers #1 and #2 work together in a single identifier of the DM8203. The Identifier consists of a concatenation of the Organizationally Unique Identifier (OUI), a vendor's model number, and a model revision number. DAVICOM Semiconductor's IEEE assigned OUI is 00606E.

Bit	Bit Name	Default	Description
15-0	OUI_MSB	<0181h>	OUI Most Significant Bits This register stores bit 3 to 18 of the OUI (00606E) to bit 15 to 0 of this register respectively. The most significant two bits of the OUI are ignored (the IEEE standard refers to these as bit 1 and 2)

8.4 PHY ID Identifier Register #2 (PHYID2) – 03H

Bit	Bit Name	Default	Description
15-10	OUI_LSB	<101110>, RO/P	OUI Least Significant Bits Bit 19 to 24 of the OUI (00606E) are mapped to bit 15 to 10 of this register respectively
9-4	VNDR_MDL	<001011>, RO/P	Vendor Model Number Five bits of vendor model number mapped to bit 9 to 4 (most significant bit to bit 9)
3-0	MDL_REV	<0000>, RO/P	Model Revision Number Five bits of vendor model revision number mapped to bit 3 to 0 (most significant bit to bit 4)

8.5 Auto-negotiation Advertisement Register (ANAR) – 04H

This register contains the advertised abilities of this DM8203 device as they will be transmitted to its link partner during Auto-negotiation.

Bit	Bit Name	Default	Description
15	NP	0,RO/P	Next page Indication 0 = No next page available 1 = Next page available The DM8203 has no next page, so this bit is permanently set to 0
14	ACK	0,RO	Acknowledge 1 = Link partner ability data reception acknowledged 0 = Not acknowledged The DM8203's auto-negotiation state machine will automatically control this bit in the outgoing FLP bursts and set it at the appropriate time during the auto-negotiation process. Software should not attempt to write to this bit.
13	RF	0, RW	Remote Fault 1 = Local device senses a fault condition 0 = No fault detected
12-11	Reserved	X, RW	Reserved Write as 0, ignore on read
10	FCS	0, RW	Flow Control Support 1 = Controller chip supports flow control ability 0 = Controller chip doesn't support flow control ability
9	T4	0, RO/P	100BASE-T4 Support 1 = 100BASE-T4 is supported by the local device 0 = 100BASE-T4 is not supported The DM8203 does not support 100BASE-T4 so this bit is permanently set to 0
8	TX_FDX	1, RW	100BASE-TX Full Duplex Support 1 = 100BASE-TX full duplex is supported by the local device 0 = 100BASE-TX full duplex is not supported
7	TX_HDX	1, RW	100BASE-TX Support 1 = 100BASE-TX half duplex is supported by the local device 0 = 100BASE-TX half duplex is not supported
6	10_FDX	1, RW	10BASE-T Full Duplex Support 1 = 10BASE-T full duplex is supported by the local device 0 = 10BASE-T full duplex is not supported
5	10_HDX	1, RW	10BASE-T Support 1 = 10BASE-T half duplex is supported by the local device 0 = 10BASE-T half duplex is not supported
4-0	Selector	<00001>, RW	Protocol Selection Bits These bits contain the binary encoded protocol selector supported by this node <00001> indicates that this device supports IEEE 802.3 CSMA/CD

8.6 Auto-negotiation Link Partner Ability Register (ANLPAR) – 05H

This register contains the advertised abilities of the link partner when received during Auto-negotiation.

Bit	Bit Name	Default	Description
15	NP	0, RO	Next Page Indication 0 = Link partner, no next page available 1 = Link partner, next page available
14	ACK	0, RO	Acknowledge 1 = Link partner ability data reception acknowledged 0 = Not acknowledged The DM8203's auto-negotiation state machine will automatically control this bit from the incoming FLP bursts. Software should not attempt to write to this bit
13	RF	0, RO	Remote Fault 1 = Remote fault indicated by link partner 0 = No remote fault indicated by link partner
12-11	Reserved	0, RO	Reserved Read as 0, ignore on write
10	FCS	0, RO	Flow Control Support 1 = Controller chip supports flow control ability by link partner 0 = Controller chip doesn't support flow control ability by link partner
9	T4	0, RO	100BASE-T4 Support 1 = 100BASE-T4 is supported by the link partner 0 = 100BASE-T4 is not supported by the link partner
8	TX_FDX	0, RO	100BASE-TX Full Duplex Support 1 = 100BASE-TX full duplex is supported by the link partner 0 = 100BASE-TX full duplex is not supported by the link partner
7	TX_HDX	0, RO	100BASE-TX Support 1 = 100BASE-TX half duplex is supported by the link partner 0 = 100BASE-TX half duplex is not supported by the link partner
6	10_FDX	0, RO	10BASE-T Full Duplex Support 1 = 10BASE-T full duplex is supported by the link partner 0 = 10BASE-T full duplex is not supported by the link partner
5	10_HDX	0, RO	10BASE-T Support 1 = 10BASE-T half duplex is supported by the link partner 0 = 10BASE-T half duplex is not supported by the link partner
4-0	Selector	<00000>, RO	Protocol Selection Bits Link partner's binary encoded protocol selector

8.7 Auto-negotiation Expansion Register (ANER) - 06H

Bit	Bit Name	Default	Description
15-5	Reserved	0, RO	Reserved Read as 0, ignore on write
4	PDF	0, RO/LH	Local Device Parallel Detection Fault PDF = 1: A fault detected via parallel detection function. PDF = 0: No fault detected via parallel detection function
3	LP_NP_ABLE	0, RO	Link Partner Next Page Able LP_NP_ABLE = 1: Link partner, next page available LP_NP_ABLE = 0: Link partner, no next page
2	NP_ABLE	0,RO/P	Local Device Next Page Able NP_ABLE = 1: DM8203, next page available NP_ABLE = 0: DM8203, no next page DM8203 does not support this function, so this bit is always 0
1	PAGE_RX	0, RO	New Page Received A new link code word page received. This bit will be automatically cleared when the register (register 6) is read by management
0	LP_AN_ABLE	0, RO	Link Partner Auto-negotiation Able A "1" in this bit indicates that the link partner supports Auto-negotiation

8.8 DAVICOM Specified Configuration Register (DSCR) – 10H

Bit	Bit Name	Default	Description
15	BP_4B5B	0,RW	Bypass 4B5B Encoding and 5B4B Decoding 1 = 4B5B encoder and 5B4B decoder function bypassed 0 = Normal 4B5B and 5B4B operation
14	BP_SCR	0, RW	Bypass Scrambler/Descrambler Function 1 = Scrambler and descrambler function bypassed 0 = Normal scrambler and descrambler operation
13	BP_ALIGN	0, RW	Bypass Symbol Alignment Function 1 = Receive functions (descrambler, symbol alignment and symbol decoding functions) bypassed. Transmit functions (symbol encoder and scrambler) bypassed 0 = Normal operation
12	BP_ADPOK	0, RW	BYPASS ADPOK Force signal detector (SD) active. This register is for debug only, not release to customer 1=Forced SD is OK, 0=Normal operation
11	Reserved	RW	Reserved Force to 0 in application
10	TX	1, RW	100BASE-TX Mode Control 1 = 100BASE-TX operation 0 = 100BASE-FX operation
9	Reserved	0, RO	Reserved



DM8203

2-port switch with MII / RMI Interface

8	Reserved	0, RW	Reserved Force to 0 in application.
7	F_LINK_100	0, RW	Force Good Link in 100Mbps 0 = Normal 100Mbps operation 1 = Force 100Mbps good link status This bit is useful for diagnostic purposes
6	Reserved	0, RW	Reserved Force to 0 in application.
5	Reserved	0, RW	Reserved Force to 0 in application.
4	RPDCTR-EN	1, RW	Reduced Power Down Control Enable This bit is used to enable automatic reduced power down 0 = Disable automatic reduced power down 1 = Enable automatic reduced power down
3	SMRST	0, RW	Reset State Machine When writes 1 to this bit, all state machines of PHY will be reset. This bit is self-clear after reset is completed
2	MFPC	1, RW	MF Preamble Suppression Control MII frame preamble suppression control bit 1 = MF preamble suppression bit on 0 = MF preamble suppression bit off
1	SLEEP	0, RW	Sleep Mode Writing a 1 to this bit will cause PHY entering the Sleep mode and power down all circuit except oscillator and clock generator circuit. When waking up from Sleep mode (write this bit to 0), the configuration will go back to the state before sleep; but the state machine will be reset
0	Reserved	0, RW	Reserved Force to 0 in application.

8.9 DAVICOM Specified Configuration and Status Register (DSCSR) – 11H

Bit	Bit Name	Default	Description																																																		
15	100FDX	1, RO	100M Full Duplex Operation Mode After auto-negotiation is completed, results will be written to this bit. If this bit is 1, it means the operation 1 mode is a 100M full duplex mode. The software can read bit [15:12] to see which mode is selected after auto-negotiation. This bit is invalid when it is not in the auto-negotiation mode																																																		
14	100HDX	1, RO	100M Half Duplex Operation Mode After auto-negotiation is completed, results will be written to this bit. If this bit is 1, it means the operation 1 mode is a 100M half duplex mode. The software can read bit [15:12] to see which mode is selected after auto-negotiation. This bit is invalid when it is not in the auto-negotiation mode																																																		
13	10FDX	1, RO	10M Full Duplex Operation Mode After auto-negotiation is completed, results will be written to this bit. If this bit is 1, it means the operation 1 mode is a 10M Full Duplex mode. The software can read bit [15:12] to see which mode is selected after auto-negotiation. This bit is invalid when it is not in the auto-negotiation mode																																																		
12	10HDX	1, RO	10M Half Duplex Operation Mode After auto-negotiation is completed, results will be written to this bit. If this bit is 1, it means the operation 1 mode is a 10M half duplex mode. The software can read bit [15:12] to see which mode is selected after auto-negotiation. This bit is invalid when it is not in the auto-negotiation mode																																																		
11	Reserved	0, RO	Reserved Read as 0, ignore on write																																																		
10	Reserved	0,RW	Reserved																																																		
9	Reserved	0,RW	Reserved																																																		
8-4	PHYADR[4:0]	0 or 1, RW	PHY Address Bit 4:0 The first PHY address bit transmitted or received is the MSB of the address (bit 4). A station management entity connected to multiple PHY entities must know the appropriate address of each PHY																																																		
3-0	ANMB[3:0]	0, RO	Auto-negotiation Monitor Bits These bits are for debug only. The auto-negotiation status will be written to these bits.																																																		
			<table border="1"> <thead> <tr> <th>B3</th> <th>B2</th> <th>B1</th> <th>B0</th> <th></th> </tr> </thead> <tbody> <tr> <td>0</td> <td>0</td> <td>0</td> <td>0</td> <td>In IDLE state</td> </tr> <tr> <td>0</td> <td>0</td> <td>0</td> <td>1</td> <td>Ability match</td> </tr> <tr> <td>0</td> <td>0</td> <td>1</td> <td>0</td> <td>Acknowledge match</td> </tr> <tr> <td>0</td> <td>0</td> <td>1</td> <td>1</td> <td>Acknowledge match fail</td> </tr> <tr> <td>0</td> <td>1</td> <td>0</td> <td>0</td> <td>Consistency match</td> </tr> <tr> <td>0</td> <td>1</td> <td>0</td> <td>1</td> <td>Consistency match fail</td> </tr> <tr> <td>0</td> <td>1</td> <td>1</td> <td>0</td> <td>Parallel detects signal link ready</td> </tr> <tr> <td>0</td> <td>1</td> <td>1</td> <td>1</td> <td>Parallel detects signal link ready fail</td> </tr> <tr> <td>1</td> <td>0</td> <td>0</td> <td>0</td> <td>Auto-negotiation completed successfully</td> </tr> </tbody> </table>	B3	B2	B1	B0		0	0	0	0	In IDLE state	0	0	0	1	Ability match	0	0	1	0	Acknowledge match	0	0	1	1	Acknowledge match fail	0	1	0	0	Consistency match	0	1	0	1	Consistency match fail	0	1	1	0	Parallel detects signal link ready	0	1	1	1	Parallel detects signal link ready fail	1	0	0	0	Auto-negotiation completed successfully
B3	B2	B1	B0																																																		
0	0	0	0	In IDLE state																																																	
0	0	0	1	Ability match																																																	
0	0	1	0	Acknowledge match																																																	
0	0	1	1	Acknowledge match fail																																																	
0	1	0	0	Consistency match																																																	
0	1	0	1	Consistency match fail																																																	
0	1	1	0	Parallel detects signal link ready																																																	
0	1	1	1	Parallel detects signal link ready fail																																																	
1	0	0	0	Auto-negotiation completed successfully																																																	

8.10 10BASE-T Configuration/Status (10BTCSR) – 12H

Bit	Bit Name	Default	Description
15	Reserved	0, RO	Reserved Read as 0, ignore on write
14	LP_EN	1, RW	Link Pulse Enable 1 = Transmission of link pulses enabled 0 = Link pulses disabled, good link condition forced This bit is valid only in 10Mbps operation
13	HBE	1,RW	Heartbeat Enable 1 = Heartbeat function enabled 0 = Heartbeat function disabled When the DM8203 is configured for full duplex operation, this bit will be ignored (the collision/heartbeat function is invalid in full duplex mode)
12	SQUELCH	1, RW	Squelch Enable 1 = Normal squelch 0 = Low squelch
11	JABEN	1, RW	Jabber Enable Enables or disables the Jabber function when the DM8203 is in 10BASE-T full duplex or 10BASE-T transceiver Loopback mode 1 = Jabber function enabled 0 = Jabber function disabled
10	SERIAL	0, RW	10Mbps Serial Mode (only valid in PHY test mode) Force to 0, in application.
9-1	Reserved	0, RO	Reserved Read as 0, ignore on write
0	POLR	0, RO	Polarity Reversed When this bit is set to 1, it indicates that the 10Mbps cable polarity is reversed. This bit is automatically set and cleared by 10BASE-T module

8.11 Power down Control Register (PWDOR) – 13H

Bit	Bit Name	Default	Description
15-9	Reserved	0, RO	Reserved Read as 0, ignore on write
8	PD10DRV	0, RW	Vendor power down control test
7	PD100DL	0, RW	Vendor power down control test
6	PDchip	0, RW	Vendor power down control test
5	PDcrm	0, RW	Vendor power down control test
4	PDaeq	0, RW	Vendor power down control test
3	PDdrv	0, RW	Vendor power down control test
2	PDedi	0, RW	Vendor power down control test
1	PDedo	0, RW	Vendor power down control test
0	PD10	0, RW	Vendor power down control test

* When selected, the power down value is control by Register 14H

8.12 (Specified config) Register – 14H

Bit	Bit Name	Default	Description
15	TSTSE1	0,RW	Vendor test select 1 control
14	TSTSE2	0,RW	Vendor test select 2 control
13	FORCE_TXSD	0,RW	Force Signal Detect 1: force SD signal OK in 100BASE-TX mode 0: normal SD signal.
12	FORCE_FEF	0,RW	Vendor test select control
11	PREAMBLEX	0,RW	Preamble Saving Control 0: when bit 10 is set, the 10BASE-T transmit preamble count is reduced. When bit 11 of register 1DH is set, 12-bit preamble is reduced; otherwise 22-bit preamble is reduced. 1: transmit preamble bit count is normal in 10BASE-T mode
10	TX10M_PWR	1,RW	10BASE-T mode Transmit Power Saving Control 1: enable transmit power saving in 10BASE-T mode 0: disable transmit power saving in 10BASE-T mode
9	NWAY_PWR	0,RW	Auto-negotiation Power Saving Control 1: disable power saving during auto-negotiation period 0: enable power saving during auto-negotiation period
8	Reserved	0, RO	Reserved Read as 0, ignore on write
7	MDIX_CNTL	MDI/MDIX,RO	The polarity of MDI/MDIX value 1: MDIX mode 0: MDI mode
6	AutoNeg_dpbk	0,RW	Auto-negotiation Loopback 1: test internal digital auto-negotiation Loopback 0: normal.
5	Mdix_fix Value	0, RW	MDIX_CNTL force value: When Mdix_down = 1, MDIX_CNTL value depend on the register value.
4	Mdix_down	0,RW	MDIX Down Manual force MDI/MDIX. 0: Enable <i>HP</i> Auto-MDIX 1: Disable <i>HP</i> Auto-MDIX , MDIX_CNTL value depend on Reg.14H.bit5
3	MonSel1	0,RW	Vendor monitor select 1
2	MonSel0	0,RW	Vendor monitor select 0
1	Reserved	0,RW	Reserved Force to 0, in application.
0	PD_value	0,RW	Power down control value Decision the value of each field Reg.13H. 1: power down 0: normal

8.13 DAVICOM Specified Receive Error Counter Register (RECR) – 16H

Bit	Bit Name	Default	Description
15-0	Rcv_Err_Cnt	0, RO	Receive Error Counter Receive error counter that increments upon detection of RXER. Clean by read this register.

8.14 DAVICOM Specified Disconnect Counter Register (DISCR) – 17H

Bit	Bit Name	Default	Description
15-8	Reserved	0, RO	Reserved
7-0	Disconnect Counter	0, RO	Disconnect Counter that increment upon detection of disconnection. Clean by read this register.

8.15 Power Saving Control Register (PSCR) – 1DH

Bit	Bit Name	Default	Description
15-12	RESERVED	0,RO	RESERVED
11	PREAMBLEX	0,RW	Preamble Saving Control when both bit 10and 11 of register 14H are set, the 10BASE-T transmit preamble count is reduced. 1: 12-bit preamble is reduced. 0: 22-bit preamble is reduced.
10	AMPLITUDE	0,RW	Transmit Amplitude Control Disabled 1: when cable is unconnected with link partner, the TX amplitude is reduced for power saving. 0: disable Transmit amplitude reduce function
9	TX_PWR	0.RW	Transmit Power Saving Control Disabled 1: when cable is unconnected with link partner, the driving current of transmit is reduced for power saving. 0: disable transmit driving power saving function
8-0	RESERVED	0,RO	RESERVED

9. Functional Description

9.1 Serial Management Interface

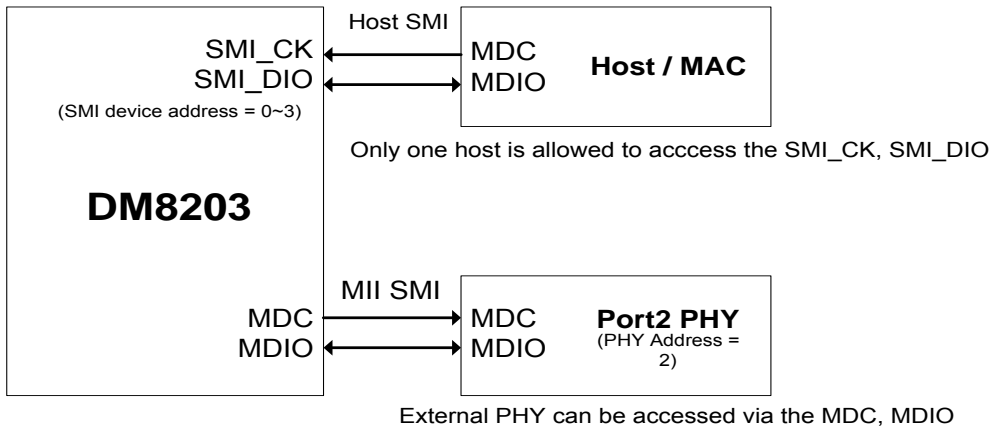

Host SMI - Read Frame Structure

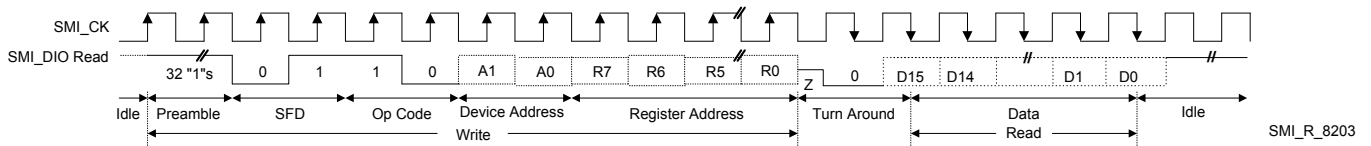

Host SMI - Write Frame Structure

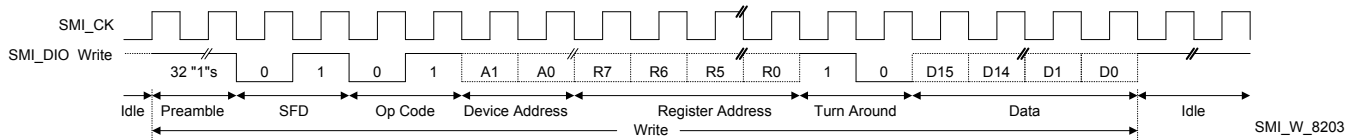

DM8203 supports two type of serial management interface (SMI), Host SMI and MII SMI. The application of SMI illustrated as below.

1. The Host SMI consists of two pins, one is SMI_CK and another is SMI_DIO. User can access DM8203's EEPROM, PHY registers, MIB counters and Configuration registers through Host SMI. The format is following. The <Device Address> field of the frame means SMI device address that is configured by strap

pin (TXD2_0 & TXD2_1). The <Register Address> field of the frame is mapped to address of control and status register set of DM8203. The read/writ data is valid on low byte (D7~D0) of <Data> field, the high byte (D15~D8) of data is reserved.

2. DM8203 supports MII SMI auto-polling for configuring speed, duplex mode, and 802.3x flow control capability of the external PHY (Port2) via the MDC, MDIO. More detail description and frame format can refer to section 9.3.2.

9.2 Switch function:

9.2.1 Address Learning

The DM8203 has a self-learning mechanism for learning the MAC addresses of incoming packets in real time. DM8203 stores MAC addresses, port number and time stamp information in the Hash-based Address Table. It can learn up to 1K unicast address entry.

The switch engine updates address table with new entry if incoming packet's Source Address (SA) does not exist and incoming packet is valid (non-error and legal length).

Besides, DM8203 has an option to disable address learning for individual port. This feature can be set by bit 0 of register 65h

9.2.2 Address Aging

The time stamp information of address table is used in the aging process. The switch engine updates time stamp whenever the corresponding SA receives. The switch engine would delete the entry if its time stamp is not updated for a period of time.

The period can be programmed or disabled through bit 0 & 1 of register 52h.

9.2.3 Packet Forwarding

The DM8203 forwards the incoming packet according to following decision:

(1). If DA is Multicast/Broadcast, the packet is forwarded to all ports, except to the port on which the packet was received.

(2). Switch engine would look up address table based on DA when incoming packets is UNICAST. If the DA was not found in address table, the packet is treated as a multicast packet and forward to other ports. If the DA was found and its destination port number is different to source port number, the packet is forward to destination port.

(3). Switch engine also look up VLAN, Port Monitor setting and other forwarding constraints for the forwarding decision, more detail will discuss in later sections.

The DM8203 will filter incoming packets under following conditions:

(1). Error packets, including CRC errors, alignment errors, illegal size errors.

(2). PAUSE packets.

(3). If incoming packet is UNICAST and its destination port number is equal to source port number.

9.2.4 Inter-Packet Gap (IPG)

IPG is the idle time between any two valid packets at the same port. The typical number is 96 bits time. In other word, the value is 9.6u sec for 10Mbps and 960n sec for 100Mbps.

9.2.5 Back-off Algorithm

The DM8203 implements the binary exponential back-off algorithm in half-duplex mode compliant to IEEE standard 802.3.

9.2.6 Late Collision

Late Collision is a type of collision. If a collision error occurs after the first 512 bit times of data are transmitted, the packet is dropped.

9.2.7 Full Duplex Flow Control

The DM8203 supports IEEE standard 802.3x flow control frames on both transmit and receive sides.

On the receive side, The DM8203 will defer transmitting next normal frames, if it receives a pause frame from link partner.

On the transmit side, The DM8203 issues pause frame with maximum pause time when internal resources such as received buffers, transmit queue and transmit descriptor ring are unavailable. Once resources are available, The DM8203 sends out a pause frame with zero pause time allows traffic to resume immediately.

9.2.8 Half Duplex Flow Control

The DM8203 supports half-duplex backpressure. The inducement is the same as full duplex mode. When flow control is required, the DM8203 sends jam pattern and results in a collision.

The flow control ability can be set in bit 4 of register 61h.

9.2.9 Partition Mode

The DM8203 provides a partition mode for each port, see bit 6 of register 61h. The port enters partition mode when more than 64 consecutive collisions are occurred. In partition mode the port continuous to transmit but it will not receive. The port returned to normal operation mode when a good packet is seen on the wire. The detail description of partition mode represent following:

(1). Entering Partition State

A port will enter the Partition State when either of the following conditions occurs:

- The port detects a collision on every one of 64 consecutive re-transmit attempts to the same packet.
- The port detects a single collision which occurs for more than 512 bit times.
- Transmit defer timer time out, which indicates the transmitting packet is deferred to long.

(2). While in Partition state:

The port will continue to transmit its pending packet, regardless of the collision detection, and will not allow the usual Back-off Algorithm. Additional packets pending for transmission will be transmitted, while ignoring the internal collision indication. This frees up the ports transmit buffers which would otherwise be filled up at the expense of other ports buffers. The assumption is that the partition is signifying a system failure situation (bad connection/cable/station), thus dropping packets is a small price to pay vs. the cost of halting the switch due to a buffer full condition.

(3). Exiting from Partition State

The Port exits from Partition State, following the end of a successful packet transmission. A successful packet transmission is defined as no collisions were detected on the first 512 bits of the transmission.

9.2.10 Broadcast Storm Filtering

The DM8203 has an option to limit the traffic of broadcast or multicast packets, to protect the switch from lower bandwidth availability.

There are two types of broadcast storm control, one is throttling broadcast packet only, the other includes multicast. This feature can be set through bit 1 of register 61h.

The broadcast storm threshold can be

programmed by EEPROM or register 67h, the default setting is no broadcast storm protecting.

9.2.11 Bandwidth Control

The DM8203 supports two types of bandwidth control for each port. One is the ingress and egress bandwidth rate can be controlled separately, the other is combined together, this function can be set through bit 3 of register 61h. The bandwidth control is disabled by default.

To separate bandwidth control mode, the threshold rate is defined in register 66h. For combined mode, it is defined in register 67h.

The behavior of bandwidth control as below:

(1).For the ingress control, if flow control function is enabled, Pause or Jam packet will be transmitted. The ingress packets will be dropped if flow control is disabled.

(2).For the egress control, the egress port will not transmit any packets. On the other hand, the ingress bandwidth of source port will be throttled that prevent packets from forwarding.

(3).In combined mode, if the sum of ingress and egress bandwidth over threshold, the bandwidth will be throttled.

9.2.12 Port Monitoring Support

The DM8203 supports "Port Monitoring" function on per port base, detail as below:

(1). Sniffer Port and Monitor Port

There is only one port can be selected as "sniffer port" by register 52h, multiple ports can be set as "receive monitor port" or "transmit monitor port" in per-port register 65h.

(2).Receive monitor

All packets received on the "receive monitor port" are send a copy to "sniffer port". For example, port 0 is set as "receive monitor port" and port 2 is selected as a "sniffer port". If a packet is received form port 0 and predestined to port 1 after forwarding decision, the DM8203 will forward it to port 1 and port 2 in the end.

(3).Transmit monitor

All packets transmitted on the "transmit monitor port" are send a copy to "sniffer port". For example, port 1 is set as "transmit monitor port" and port 2 is selected as "sniffer port". If a packet is received from port 0 and predestined to port 1 after forwarding decision, the DM8203 will forward it to port 1 and port

2 in the end.

(4).Exception

The DM8203 has an optional setting that broadcast/multicast packets are not monitored (see bit 4 of register 65h). It's useful to avoid unnecessary bandwidth.

- (1). Set PVID of Port 0 to 0x01h.
- (2). Set PVID of Port 1 to 0x02h.
- (3). Set PVID of Port 2 to 0x03h.
- (4). Set register B1h to 0x06h.
- (5). Set register B2h to 0x05h.
- (6). Set register B3h to 0x03h.

9.2.13 VLAN Support

9.2.13.1 Port-Based VLAN

The DM8203 supports port-based VLAN as default, up to 16 groups. Each port has a default VID called PVID (Port VID, see register 6Fh). The DM8203 used LSB 4-bytes of PVID as index and mapped to register B0h~BFh, to define the VLAN groups.

For instance, we intend to partition DM8203's ports into three groups. Port 0 and port 1 in group A, port 1 and port 2 in group B, finally, port 2 and port 0 in group C. In this case, the setting as below:

9.2.13.2 802.1Q-Based VLAN

Regarding IEEE 802.1Q standard, Tag-based VLAN uses an extra tag to identify the VLAN membership of a frame across VLAN-aware switch/router. A tagged frame is four bytes longer than an untagged frame and contains two bytes of TPID (Tag Protocol Identifier) and two bytes of TCI (Tag Control Information).

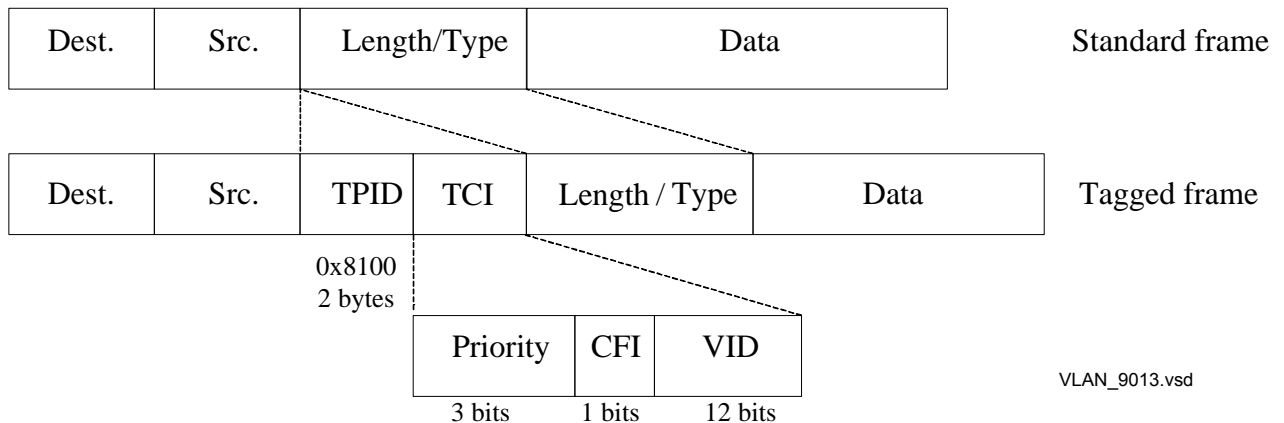

The DM8203 also supports 16 802.1Q-based VLAN groups, as specified in bit 1 of register 53h. It's obvious that the tagged packets can be assigned to several different VLANs which are determined according to the VID inside the VLAN Tag. Therefore, the operation is similar to port-based VLAN. The DM8203 used LSB 4-bytes VID of received packet with VLAN tag and VLAN Group Mapping Register (B0h~BFh) to configure the VLAN partition. If the destination port of received packet is not same VLAN group with received port, it will be discarded.

User can define each port as Tag port or Un-tag port by bit 7 of register 6Dh in 802.1Q-based VLAN mode. The operation of Tag and Un-tag can explain as below conditions:

- (1). Receive untagged packet and forward to Un-tag port.
Received packet will forward to destination port without modification.
- (2). Receive tagged packet and forward to Un-tag port.
The DM8203 will remove the tag from the packet and recalculate CRC before sending it out.
- (3). Receive untagged packet and forward to Tag port.

9.2.13.3 Tag/Untag

The DM8203 will insert the PVID tag when an untagged packet enters the port, and recalculate CRC before delivering it.

(4). Receive tagged packet and forward to Tag port.

Received packet will forward to destination port without modification.

9.2.14 Priority Support

The DM8203 supports Quality of Service (QoS) mechanism for multimedia communication such as VoIP and video conferencing.

The DM8203 provides three priority classifications: Port-based, 802.1p-based and DiffServ-based priority. See next section for more detail. The DM8203 offers four level queues for transmit on per-port based.

The DM8203 provides two packet scheduling algorithms: Weighted Fair Queuing and Strict Priority Queuing. Weighted Fair Queuing (WFQ) based on their priority and queue weight. Queues with larger weights get more service than smaller. This mechanism can get highly efficient bandwidth and smooth the traffic. Strict Priority Queuing (SPQ) based on priority only. The Packet on the highest priority queue is transmitted first. The next highest-priority queue is work until last queue empties, and so on. This feature can be set in bit 5 of register 6Dh.

9.2.14.1 Port-Based Priority

Port based priority is the simplest scheme and as default. Each port has a 2-bit priority value as index for splitting ingress packets to the corresponding transmit queue. This value can be set in bit 0 and 1 of register 6Dh.

9.2.14.2 802.1p-Based Priority

802.1p priority can be disabled by bit 2 of register 6Dh, it is enabled by default.

The DM8203 extracts 3-bit priority field from received packet with 802.1p VLAN tag, and maps this field against VLAN Priority Map Registers (D0h~D1h) to determine which transmit queue is designated. The VLAN Priority Map is programmable.

9.2.14.3 DiffServ-Based Priority

DiffServ based priority uses the most significant 6-bit of the ToS field in standard IPv4 header, and maps this field against ToS Priority Map Registers (C0h~CFh) to determine which transmit queue is designated. The ToS Priority Map is programmable too. In addition, User can only refer to most significant 3-bit of the ToS field optionally, see bit 7 of register 53h.

9.3 MII Interface

9.3.1 MII data interface

The DM8203 port 2 provides a Media Independent Interface (MII) as defined in the IEEE 802.3u standard (Clause 22).

The MII consists of a nibble wide receive data bus, a nibble wide transmit data bus, and control signals to facilitate data transfers between the DM8203 port 2 and external device (a PHY or a MAC in reverse MII).

- TXD2 (transmit data) is a nibble (4 bits) of data that are driven by the DM8203 synchronously with respect to TXC2. For each TXC2 period, which TXE2 is asserted, TXD2 (3:0) are accepted for transmission by the external device.
- TXC2 (transmit clock) from the external device is a continuous clock that provides the timing reference for the transfer of the TXE2, TXD2. The DM8203 can drive 25MHz clock if it is configured to reversed MII mode.
- TXE2 (transmit enable) from the DM8203 port 2 MAC indicates that nibbles are being presented on the MII for transmission to the external device.
- RXD2 (receive data) is a nibble (4 bits) of data that are sampled by the DM8203 port 2 MAC synchronously with respect to RXC2. For each RXC2 period which RXDV2 is asserted, RXD2 (3:0) are transferred from the external device to the DM8203 port 2 MAC reconciliation sub layer.
- RXC2 (receive clock) from external device to the DM8203 port 2 MAC reconciliation sub layer is a continuous clock that provides the timing reference for the transfer of the RXDV2, RXD2, and RXER2 signals.
- RXDV2 (receive data valid) input from the external device to indicates that the external device is presenting recovered and decoded nibbles to the DM8203 port 2 MAC reconciliation sub layer. To interpret a receive frame correctly by the reconciliation sub layer, RXDV2 must encompass the frame, starting no later than the Start-of-Frame delimiter and excluding any End-Stream delimiter.
- RXER2 (receive error) input from the external device is synchronously with respect to RXC2. RXER2 will be asserted for 1 or more clock periods to indicate to the reconciliation sub layer that an error was detected somewhere in the frame being

transmitted from the external device to the DM8203 port 2 MAC.

- CRS2 (carrier sense) is asserted by the external device when either the transmit or receive medium is non-idle, and de-asserted by the external device when the transmit and receive medium are idle. The CRS2 can also in output mode when the DM8203 port 2 is configured to reversed MII mode.
- COL2 (collision detection) is asserted by the external device, when both the transmit and receive medium is non-idle, and de-asserted by the external device when the either transmit or receive medium are idle. The COL2 can also in output mode when the DM8203 port 2 is configured to reversed MII mode.

9.3.2 MII Serial Management

The MII serial management interface consists of a data interface, basic register set in DM8203 port 0 and 1, and a serial management interface to the register set. Through this interface it is possible to control and configure multiple PHY devices, include internal two ports, get status and error information, and determine the type and capabilities of the attached PHY device(s). The DM8203 default is polling 3 ports basic registers 0, 1, 4, and 5 to get the link, duplex, and speed status automatically. Alternatively, the DM8203 can be programmed to read or write any registers of 3 ports by section 6.8~11 CSR B, C, D, and E.

The DM8203 management functions correspond to MII specification for IEEE 802.3u-1995 (Clause 22) for registers 0 through 6 with vendor-specific registers 16,17, 18, 21, 22, 23 and 24~27.

In read/write operation, the management data frame is 64-bits long and starts with 32 contiguous logic one bits (preamble) synchronization clock cycles on MDC. The Start of Frame Delimiter (SFD) is indicated by a <01> pattern followed by the operation code (OP) :< 10> indicates Read operation and <01> indicates Write operation. For read operation, a 2-bit turnaround (TA) filing between Register Address field and Data field is provided for MDIO to avoid contention. Following the turnaround time, 16-bit data is read from or written onto management registers.

9.3.3 Serial Management Interface

The serial control interface uses a simple two-wired serial interface to obtain and control the status of the physical layer through the MII interface. The serial control interface consists of MDC (Management Data Clock), and MDI/O (Management Data Input/Output) signals.

The MDIO pin is bi-directional and may be shared by up to 32 devices.

9.3.4 Management Interface - Read Frame Structure

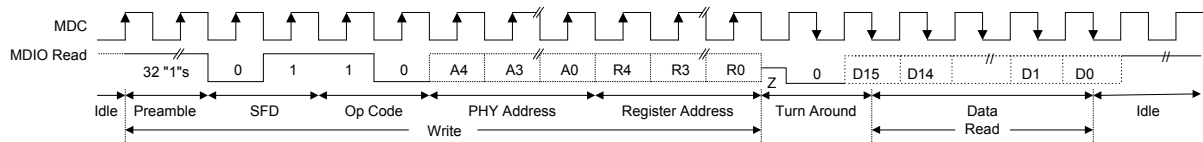

9.3.5 Management Interface - Write Frame Structure

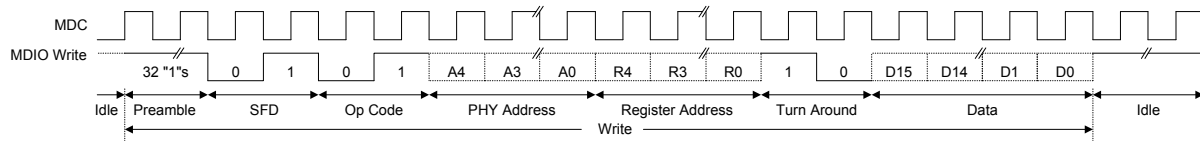

9.4 Internal PHY functions

9.4.1 100Base-TX Operation

The transmitter section contains the following functional blocks:

- 4B5B Encoder
- Scrambler
- Parallel to Serial Converter
- NRZ to NRZI Converter
- NRZI to MLT-3
- MLT-3 Driver

9.4.1.1 4B5B Encoder

The 4B5B encoder converts 4-bit (4B) nibble data generated by the MAC Reconciliation Layer into a 5-bit (5B) code group for transmission, see reference Table 1. This conversion is required for control and packet data to be combined in code groups. The 4B5B encoder substitutes the first 8 bits of the MAC preamble with a J/K code-group pair (11000 10001) upon transmit. The 4B5B encoder continues to replace subsequent 4B preamble and data nibbles with corresponding 5B code-groups. At the end of the transmit packet, upon the deservations of the Transmit Enable signal from the MAC Reconciliation layer, the 4B5B encoder injects the T/R code-group pair (01101 00111) indicating the end of frame. After the T/R code-group pair, the 4B5B encoder continuously injects IDLEs into the transmit data stream until Transmit Enable is asserted and the next transmit packet is detected.

9.4.1.2 Scrambler

The scrambler is required to control the radiated emissions (EMI) by spreading the transmit energy across the frequency spectrum at the media connector and on the twisted pair cable in 100Base-TX operation.

By scrambling the data, the total energy presented to the cable is randomly distributed over a wide frequency range. Without the scrambler, energy levels on the cable could peak beyond FCC limitations at frequencies related to the repeated 5B sequences, like the continuous transmission of IDLE symbols. The scrambler output is combined with the NRZ 5B data from the code-group encoder via an XOR logic function. The result is a scrambled data stream with sufficient randomization to decrease radiated emissions at critical frequencies.

9.4.1.3 Parallel to Serial Converter

The Parallel to Serial Converter receives parallel 5B scrambled data from the scrambler, and serializes it (converts it from a parallel to a serial data stream). The serialized data stream is then presented to the NRZ to NRZI encoder block

9.4.1.4 NRZ to NRZI Encoder

After the transmit data stream has been scrambled and serialized, the data must be NRZI encoded for compatibility with the TP-PMD standard, for 100Base-TX transmission over Category-5 unshielded twisted pair cable.

9.4.1.5 MLT-3 Converter

The MLT-3 conversion is accomplished by converting The data stream output, from the NRZI encoder into two binary data streams, with alternately phased logic One event.

9.4.1.6 MLT-3 Driver

The two binary data streams created at the MLT-3 converter are fed to the twisted pair output driver, which converts these streams to current sources and alternately drives either side of the transmit transformer's primary winding, resulting in a minimal current MLT-3 signal.

9.4.1.7 4B5B Code Group

Symbol	Meaning	4B code 3210	5B Code 43210
0	Data 0	0000	11110
1	Data 1	0001	01001
2	Data 2	0010	10100
3	Data 3	0011	10101
4	Data 4	0100	01010
5	Data 5	0101	01011
6	Data 6	0110	01110
7	Data 7	0111	01111
8	Data 8	1000	10010
9	Data 9	1001	10011
A	Data A	1010	10110
B	Data B	1011	10111
C	Data C	1100	11010
D	Data D	1101	11011
E	Data E	1110	11100
F	Data F	1111	11101
I	Idle	undefined	11111
J	SFD (1)	0101	11000
K	SFD (2)	0101	10001
T	ESD (1)	undefined	01101
R	ESD (2)	undefined	00111
H	Error	undefined	00100
V	Invalid	undefined	00000
V	Invalid	undefined	00001
V	Invalid	undefined	00010
V	Invalid	undefined	00011
V	Invalid	undefined	00101
V	Invalid	undefined	00110
V	Invalid	undefined	01000
V	Invalid	undefined	01100
V	Invalid	undefined	10000
V	Invalid	undefined	11001

Table 1

9.4.2 100Base-TX Receiver

The 100Base-TX receiver contains several function blocks that convert the scrambled 125Mb/s serial data to synchronous 4-bit nibble data.

The receive section contains the following functional blocks:

- Signal Detect
- Digital Adaptive Equalization
- MLT-3 to Binary Decoder
- Clock Recovery Module
- NRZI to NRZ Decoder
- Serial to Parallel
- Descrambler
- Code Group Alignment
- 4B5B Decoder

9.4.2.1 Signal Detect

The signal detects function meets the specifications mandated by the ANSI XT12 TP-PMD 100Base-TX standards for both voltage thresholds and timing parameters.

9.4.2.2 Adaptive Equalization

When transmitting data over copper twisted pair cable at high speed, attenuation based on frequency becomes a concern. In high speed twisted pair signaling, the frequency content of the transmitted signal can vary greatly during normal operation based on the randomness of the scrambled data stream. This variation in signal attenuation, caused by frequency variations, must be compensated for to ensure the integrity of the received data. In order to ensure quality transmission when employing MLT-3 encoding, the compensation must be able to adapt to various cable lengths and cable types depending on the installed environment. The selection of long cable lengths for a given implementation requires significant compensation, which will be over-killed in a situation that includes shorter, less attenuating cable lengths. Conversely, the selection of short or intermediate cable lengths requiring less compensation will cause serious under-compensation for longer length cables. Therefore, the compensation or equalization must be adaptive to ensure proper conditioning of the received signal independent of the cable length.

9.4.2.3 MLT-3 to NRZI Decoder

The DM8203 decodes the MLT-3 information from the Digital Adaptive Equalizer into NRZI data.

9.4.2.4 Clock Recovery Module

The Clock Recovery Module accepts NRZI data from the MLT-3 to NRZI decoder. The Clock Recovery Module locks onto the data stream and extracts the 125 MHz reference clock. The extracted and synchronized clock and data are presented to the NRZI to NRZ decoder.

9.4.2.5 NRZI to NRZ

The transmit data stream is required to be NRZI encoded for compatibility with the TP-PMD standard for 100Base-TX transmission over Category-5 unshielded twisted pair cable. This conversion process must be reversed on the receive end. The NRZI to NRZ decoder receives the NRZI data stream from the Clock Recovery Module and converts it to a NRZ data stream to be presented to the Serial to Parallel conversion block.

9.4.2.6 Serial to Parallel

The Serial to Parallel Converter receives a serial data stream from the NRZI to NRZ converter. It converts the data stream to parallel data to be presented to the descrambler.

9.4.2.7 Descrambler

Because of the scrambling process requires to control the radiated emissions of transmit data streams, the receiver must descramble the receive data streams. The descrambler receives scrambled parallel data streams from the Serial to Parallel converter, and it descrambles the data streams, and presents the data streams to the Code Group alignment block.

9.4.2.8 Code Group Alignment

The Code Group Alignment block receives un-aligned 5B data from the descrambler and converts it into 5B code group data. Code Group Alignment occurs after the J/K is detected and subsequent data is aligned on a fixed boundary.

9.4.2.9 4B5B Decoder

The 4B5B Decoder functions as a look-up table that translates incoming 5B code groups into 4B (Nibble) data. When receiving a frame, the first 2 5-bit code groups receive the start-of-frame delimiter (J/K symbols). The J/K symbol pair is stripped and two nibbles of preamble pattern are substituted. The last two code groups are the end-of-frame delimiter (T/R Symbols).

The T/R symbol pair is also stripped from the nibble, presented to the Reconciliation layer.

9.4.3 10Base-T Operation

The 10Base-T transceiver is IEEE 802.3u compliant. When the DM8203 is operating in 10Base-T mode, the coding scheme is Manchester. Data processed for transmit is presented in nibble format, converted to a serial bit stream, then the Manchester encoded. When receiving, the bit stream, encoded by the Manchester, is decoded and converted into nibble format.

9.4.4 Collision Detection

For half-duplex operation, a collision is detected when the transmit and receive channels are active simultaneously. Collision detection is disabled in full duplex operation.

9.4.5 Carrier Sense

Carrier Sense (CRS) is asserted in half-duplex operation during transmission or reception of data. During full-duplex mode, CRS is asserted only during Receive operations.

9.4.6 Auto-Negotiation

The objective of Auto-negotiation is to provide a means to exchange information between linked devices and to automatically configure both devices to take maximum advantage of their abilities. It is important to note that Auto-negotiation does not test the characteristics of the linked segment. The Auto-Negotiation function provides a means for a device to advertise supported modes of operation to a remote link partner, acknowledge the receipt and understanding of common modes of operation, and to reject un-shared modes of operation. This allows devices on both ends of a segment to establish a link at the best common mode of operation. If more than one common mode exists between the two devices, a mechanism is provided to allow the devices to resolve to a single mode of operation using a predetermined priority resolution function.

Auto-negotiation also provides a parallel detection function for devices that do not support the Auto-negotiation feature. During Parallel detection there is no exchange of information of configuration. Instead, the receive signal is examined. If it is discovered that the signal matches a technology, which the receiving device supports, a connection will be automatically established using that technology. This allows devices not to support Auto-negotiation but support a common mode of operation to establish a link.

9.5 HP Auto-MDIX Functional Descriptions

The DM8203 supports the automatic detect cable connection type, MDI/MDIX (straight through/cross over). A manual configuration by register bit for MDI or MDIX is still accepted.

When set to automatic, the polarity of MDI/MDIX controlled timing is generated by 16-bits LFSR. The switching cycle time is located from 200ms to 420ms. The polarity control is always switch until detect received signal. After selected MDI or MDIX, This feature is able to detect the required cable connection type. (Straight through or crossed over) and make correction automatically

RX + /- from DM8203

RX+/- to RJ45

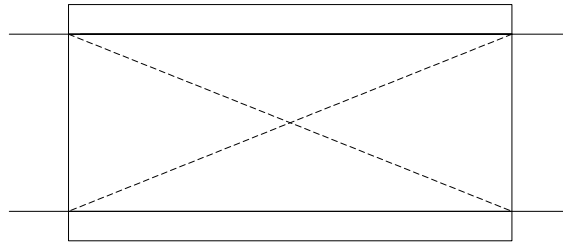

TX + /- from DM8203

TX+/- to RJ45

* MDI: _____

* MDIX: - - - - -

10. DC and AC Electrical Characteristics

10.1 Absolute Maximum Ratings

Symbol	Parameter	Min.	Max.	Unit	Conditions
VCC3	3.3V Supply Voltage	-0.3	3.6	V	
VCCI	1.8V core power supply	-0.3	1.95	V	
AVDD3	Analog power supply 3.3V	-0.3	3.6	V	
AVDDI	Analog power supply 1.8V	-0.3	1.95	V	
V _{IN}	DC Input Voltage (VIN)	-0.5	5.5	V	
T _{STG}	Storage Temperature range	-65	+150	°C	
T _A	Ambient Temperature	0	+70	°C	
L _T	Lead Temperature (TL, soldering, 10 sec.).	-	+260	°C	Lead-free Device

10.2 Operating Conditions

Symbol	Parameter	Min.	Typ.	Max.	Unit	Conditions
VCC3	3.3V Supply Voltage	3.135	-	3.465	V	-
VCCI	1.8V core power supply	1.71	-	1.89	V	-
AVDD3	Analog power supply 3.3V	3.135	-	3.465	V	-
AVDDI	Analog power supply 1.8V	1.71	-	1.89	V	-
P _D (Power Dissipation)	100BASE-TX	-	230	-	mA	1.8V only
		-	70	-	mA	3.3V only
	10BASE-TX	-	140	-	mA	TX idle, 1.8V only
		-	250	-	mA	50% utilization, 1.8V only
		-	360	-	mA	100% utilization, 1.8V only
	Auto-negotiation or cable off	-	30	-	mA	3.3V only
		-	170	-	mA	1.8V only
		-	40	-	mA	3.3V only

10.3 DC Electrical Characteristics

Symbol	Parameter	Min.	Typ.	Max.	Unit	Conditions
Inputs						
VIL	Input Low Voltage	-	-	0.8	V	Vcond1
VIH	Input High Voltage	2.0	-	-	V	Vcond1
IIL	Input Low Leakage Current	-1	-	-	uA	VIN = 0.0V, Vcond1
IIH	Input High Leakage Current	-	-	1	uA	VIN = 3.3V, Vcond1
Outputs						
VOL	Output Low Voltage	-	-	0.4	V	IOL = 4mA
VOH	Output High Voltage	2.4	-	-	V	IOH = -4mA
Receiver						
VICM	RX+/RX- Common Mode Input Voltage	-	1.8	-	V	100 Ω Termination Across
Transmitter						
VTD100	100TX+/- Differential Output Voltage	1.9	2.0	2.1	V	Peak to Peak
VTD10	10TX+/- Differential Output Voltage	4.4	5	5.6	V	Peak to Peak
ITD100	100TX+/- Differential Output Current	19	20	21	mA	Absolute Value
ITD10	10TX+/- Differential Output Current	44	50	56	mA	Absolute Value

Note: Vcond1 = VCC3 = 3.3V, VCCI = 1.8V, AVDD3 = 3.3V, AVDDI = 1.8V.

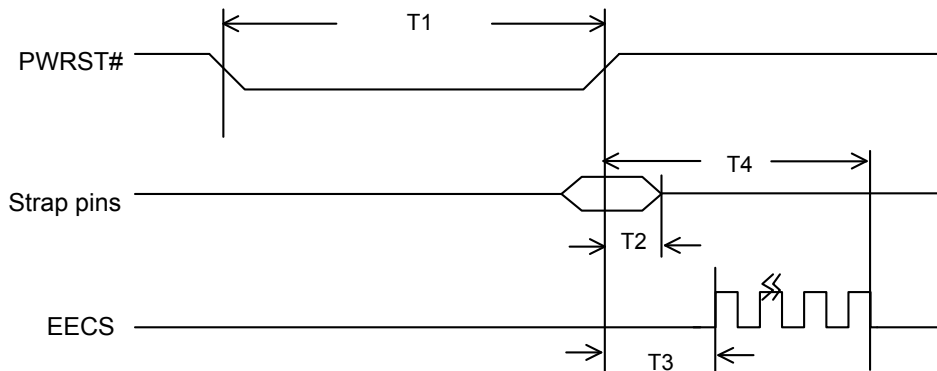
10.4 AC characteristics
10.4.1 Power On Reset Timing

Symbol	Parameter	Min.	Typ.	Max.	Unit	Conditions
T1	PWRST# Low Period	1	-	-	ms	-
T2	Strap pin hold time with PWRST#	40	-	-	ns	-
T3	PWRST# high to EECS high	-	5	-	us	
T4	PWRST# high to EECS burst end	-	--	4	ms	

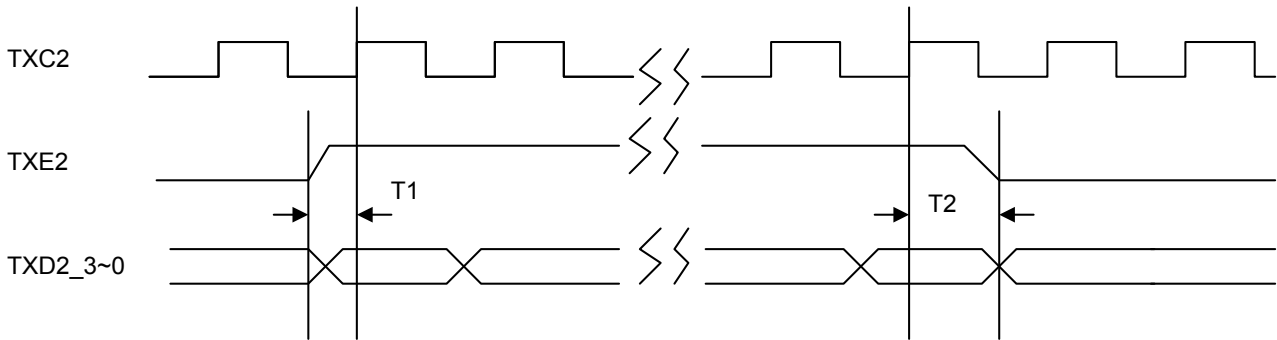
10.4.2 Port 2 MII Interface Transmit Timing

Symbol	Parameter	Min.	Typ.	Max.	Unit
T1	TXE2, TXD2_3~0 Setup Time		32		ns
T2	TXE2, TXD2_3~0 Hold Time		8		ns

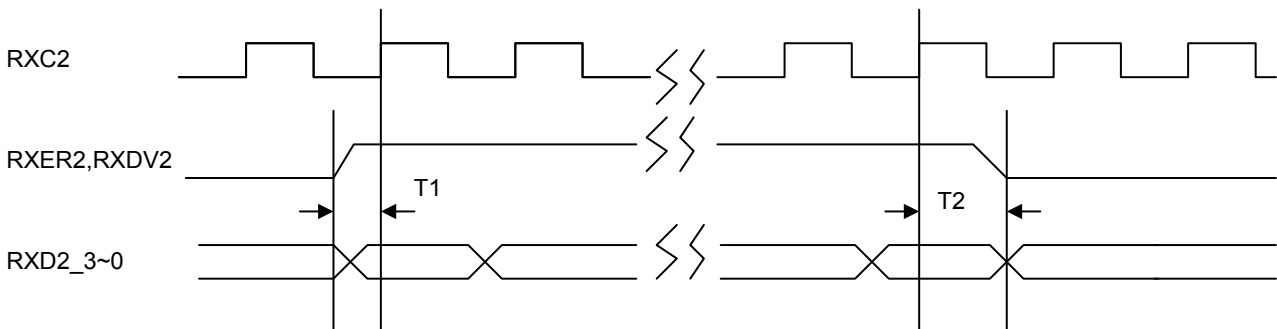
10.4.3 Port 2 MII Interface Receive Timing

Symbol	Parameter	Min.	Typ.	Max.	Unit
T1	RXER2, RXDV2, RXD2_3~0 Setup Time	5			ns
T2	RXER2, RXDV2, RXD2_3~0 Hold Time	5			ns

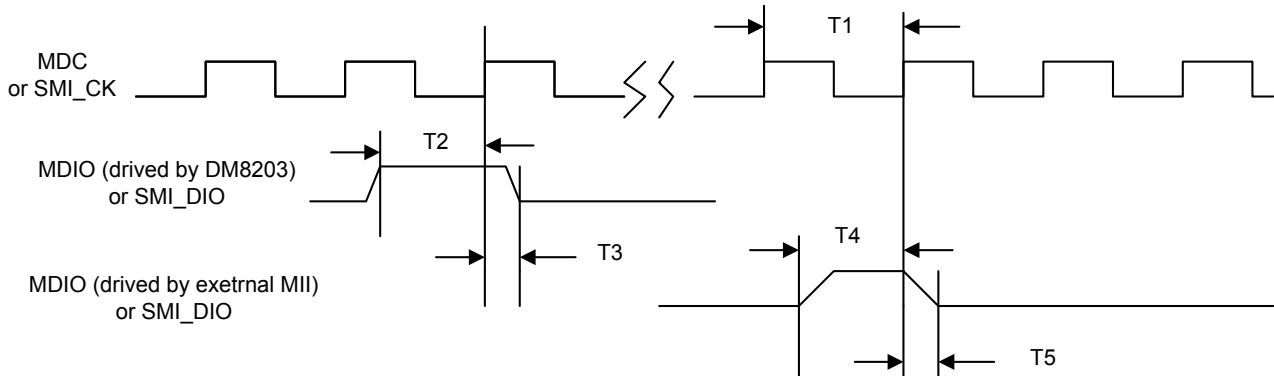
10.4.4 MII Management or host SMI Interface Timing

Symbol	Parameter	Min.	Typ.	Max.	Unit
T1	MDC or SMI_CK Frequency		0.52		MHz
T2	MDIO or SMI_DIO by DM8203 Setup Time		955		ns
T3	MDIO or SMI_DIO by DM8203 Hold Time		960		ns
T4	MDIO or SMI_DIO by External MII Setup Time	40			ns
T5	MDIO or SMI_DIO by External MII Hold Time	40			ns

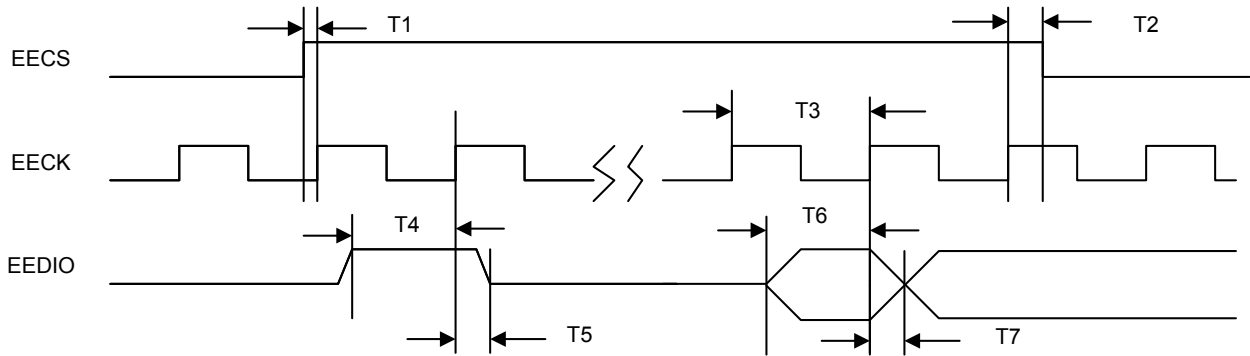
10.4.5 EEPROM timing

Symbol	Parameter	Min.	Typ.	Max.	Unit
T1	EECS Setup Time		480		ns
T2	EECS Hold Time		2080		ns
T3	EECK Frequency		0.38		MHz
T4	EEDIO Setup Time in output state		460		ns
T5	EEDIO Hold Time in output state		2100		ns
T6	EEDIO Setup Time in input state	8			ns
T7	EEDIO Hold Time in input state	8			ns

11. Application circuit

11.1 Main circuit

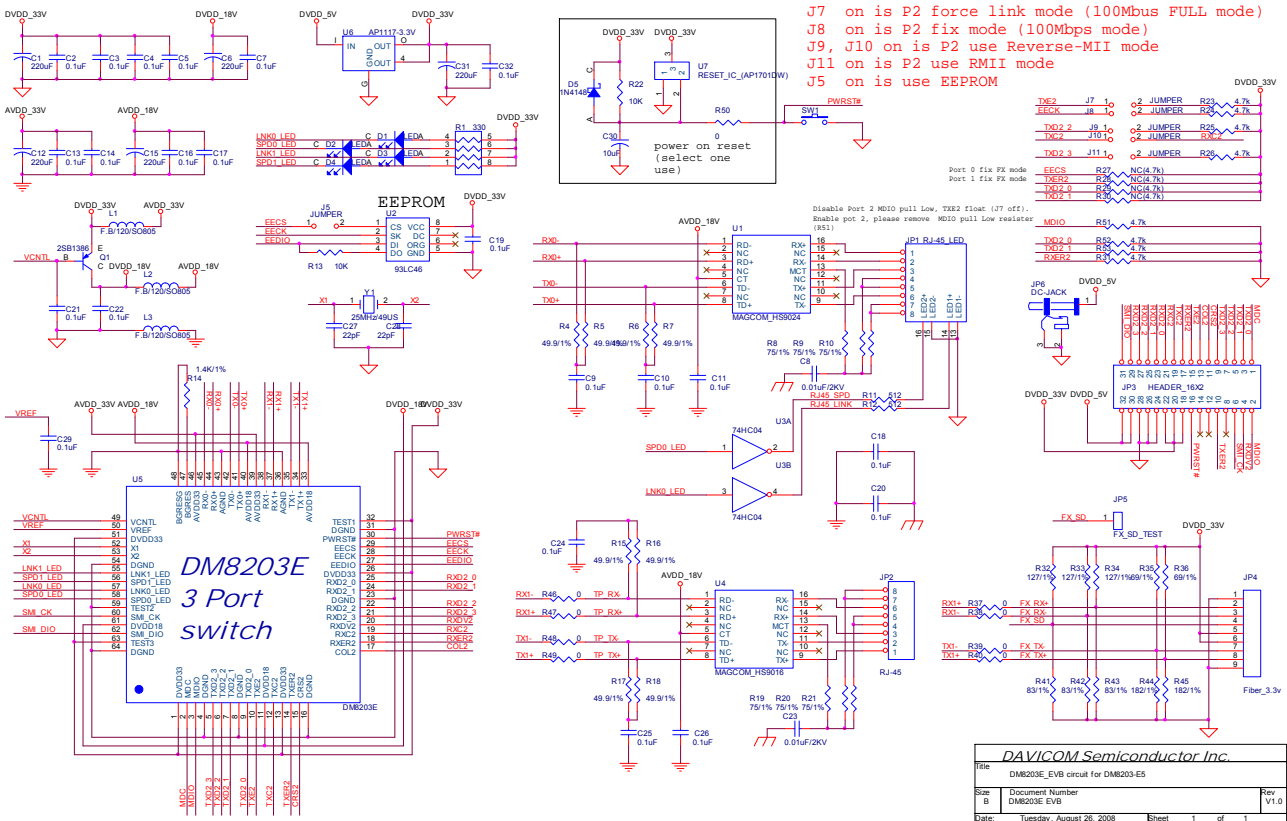

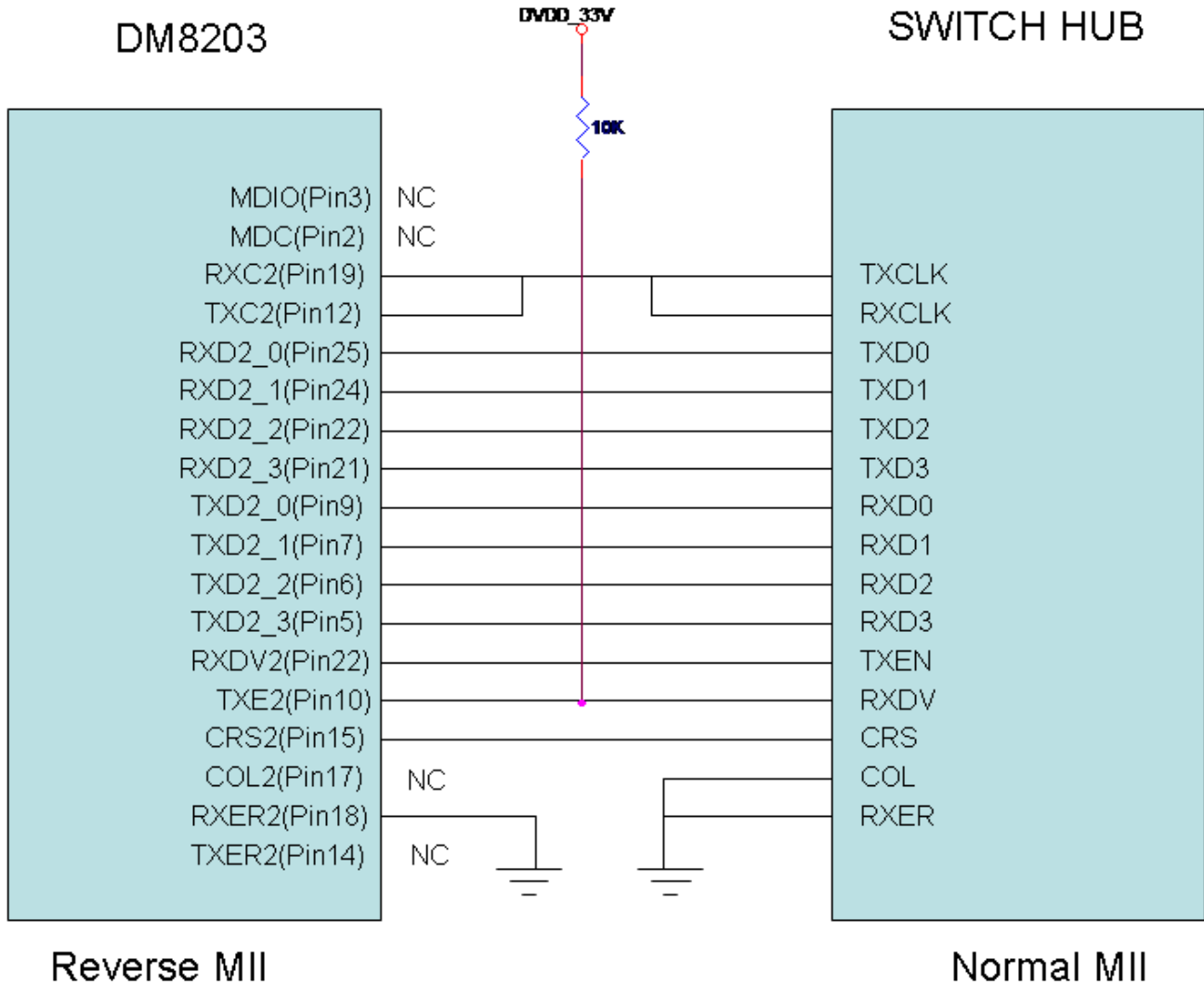
11.2 Application of Reverse MII

Application of Reverse MII

12. Package Information

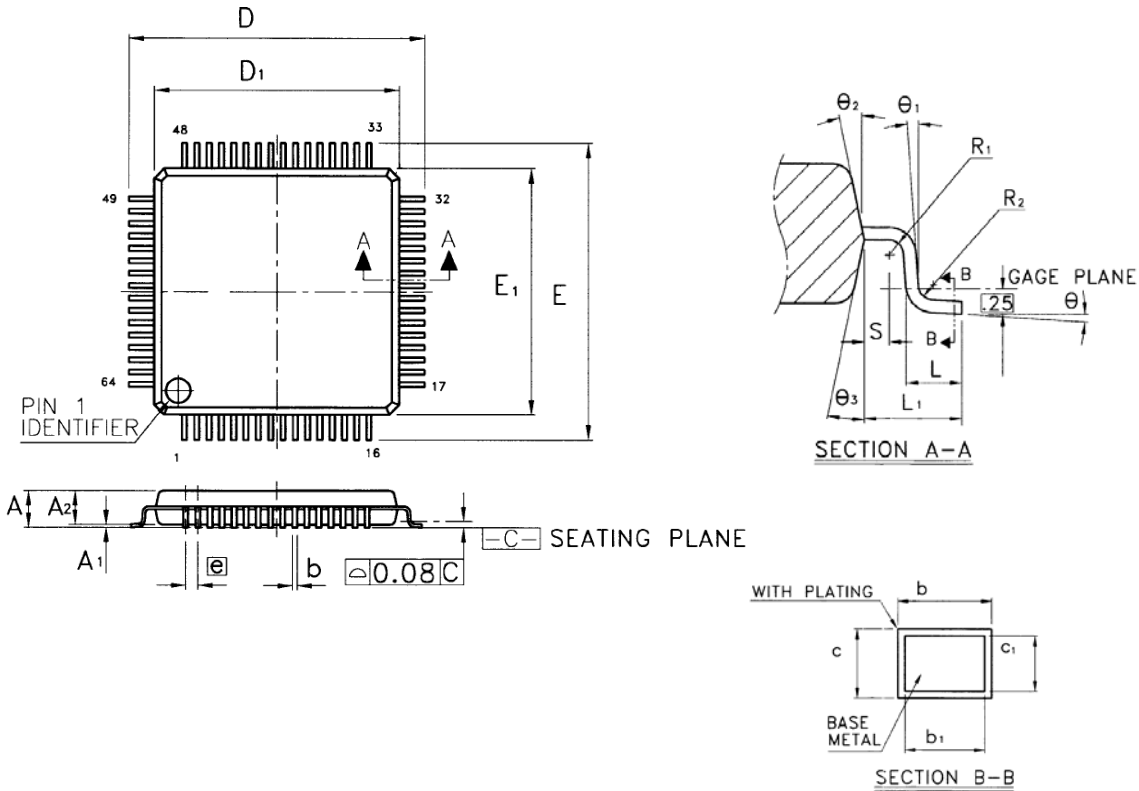
64 Pins LQFP Package Outline Information:



Symbol	Dimension in mm			Dimension in inch		
	Min	Nom	Max	Min	Nom	Max
A	-	-	1.60	-	-	0.063
A ₁	0.05	-	0.15	0.002	-	0.006
A ₂	1.35	1.40	1.45	0.053	0.055	0.057
b	0.17	0.22	0.27	0.007	0.009	0.011
b ₁	0.17	0.20	0.23	0.007	0.008	0.009
c	0.09	-	0.20	0.004	-	0.008
c ₁	0.09	-	0.16	0.004	-	0.006
D	12.00 BSC			0.472 BSC		
D ₁	10.00 BSC			0.394 BSC		
E	12.00 BSC			0.472 BSC		
E ₁	10.00 BSC			0.394 BSC		
⓪	0.50 BSC			0.020 BSC		
L	0.45	0.60	0.75	0.018	0.024	0.030
L ₁	1.00 REF			0.039 REF		
R ₁	0.08	-	-	0.003	-	-
R ₂	0.08	-	0.20	0.003	-	0.008
S	0.20	-	-	0.008	-	-
θ	0°	3.5°	7°	0°	3.5°	7°
θ ₁	0°	-	-	0°	-	-
θ ₂	12° TYP			12° TYP		
θ ₃	12° TYP			12° TYP		

1. Dimension D₁ and E₁ do not include resin fin.
2. All dimensions are base on metric system.
3. General appearance spec should base on its final visual inspection spec.

13. Ordering Information

Part Number	Pin Count	Package
DM8203EP	64	LQFP (Pb-free)

Disclaimer

The information appearing in this publication is believed to be accurate. Integrated circuits sold by DAVICOM Semiconductor are covered by the warranty and patent indemnification provisions stipulated in the terms of sale only. DAVICOM makes no warranty, express, statutory, implied or by description regarding the information in this publication or regarding the information in this publication or regarding the freedom of the described chip(s) from patent infringement. FURTHER, DAVICOM MAKES NO WARRANTY OF MERCHANTABILITY OR FITNESS FOR ANY PURPOSE. DAVICOM reserves the right to halt production or alter the specifications and prices at any time without notice. Accordingly, the reader is cautioned to verify that the data sheets and other information in this publication are current before placing orders. Products described herein are intended for use in normal commercial applications. Applications involving unusual environmental or reliability requirements, e.g. military equipment or medical life support equipment, are specifically not recommended without additional processing by DAVICOM for such applications. Please note that application circuits illustrated in this document are for

reference purposes only.

DAVICOM's terms and conditions printed on the order acknowledgment govern all sales by DAVICOM. DAVICOM will not be bound by any terms inconsistent with these unless DAVICOM agrees otherwise in writing. Acceptance of the buyer's orders shall be based on these terms.

Company Overview

DAVICOM Semiconductor Inc. develops and manufactures integrated circuits for integration into data communication products. Our mission is to design and produce IC products that are the industry's best value for Data, Audio, Video, and Internet/Intranet applications. To achieve this goal, we have built an organization that is able to develop chipsets in response to the evolving technology requirements of our customers while still delivering products that meet their cost requirements.

Products

We offer only products that satisfy high performance requirements and which are compatible with major hardware and software standards. Our currently available and soon to be released products are based on our proprietary designs and deliver high quality, high performance chipsets that comply with modem communication standards and Ethernet networking standards.

Contact Windows

For additional information about DAVICOM products, contact the Sales department at:

Headquarters

Hsin-chu Office:

No.6 Li-Hsin Rd. VI,
Science-based Park,
Hsin-chu City, Taiwan, R.O.C.
TEL: +886-3-5798797
FAX: +886-3-5646929
MAIL: sales@davicom.com.tw
HTTP: <http://www.davicom.com.tw>

WARNING

Conditions beyond those listed for the absolute maximum may destroy or damage the products. In addition, conditions for sustained periods at near the limits of the operating ranges will stress and may temporarily (and permanently) affect and damage structure, performance and/or function.